

# CATALOGO ACCESSORI ACCESSORIES/ CATALOGUE



RICAMBI



GARDOSI  
dal 1958

## IL NOSTRO SITO WEB

Uno strumento innovativo ed unico sviluppato pensando all'utilizzatore finale che permette una ricerca veloce ed intuitiva.

Gentile Cliente, abbiamo la possibilità di ricevere i tuoi ordini anche online attraverso il nostro sito web ufficiale sul quale saranno sempre aggiornate le tavole esplose e le ricerche fotografiche.

Per richieste particolari e domande di ogni tipo, chiamaci direttamente a questi recapiti:



Tel. +39 051 756075  
Fax. + 39 051 756640



E-mail: [info@ricambigardosi.it](mailto:info@ricambigardosi.it)

Condizioni generali di vendita e term of use consultabili on line nella sezione "servizio clienti" Ricambigardosi S.r.l. - Tutti i diritti riservati. Nessuna porzione di questo documento può essere riprodotta, Immagazzinata in sistemi magnetici o trascritta, in qualsiasi forma e con qualsiasi mezzo, senza l'autorizzazione scritta della Ricambigardosi S.r.l.

## OUR WEBSITE

The website shall provide a unique, innovative instrument with fast, intuitive search capabilities, tailored to end-user needs.

Dear Client we have the possibility to receive your orders online through our official website which will be updated the exploded drawings and photographic research.

If you have a special request and for infos of any kind, please contact us directly:



Tel. +39 051 756075  
Fax. + 39 051 756640



E-mail: [info@ricambigardosi.it](mailto:info@ricambigardosi.it)

Conditions ans sales terms and term of use available online in the "customer service" Ricambigardosi S.r.l. - All rights reserved. No portions in this document may be reproduced, stored in magnetic systems, or transcribed, in any form and by any means, without written authorization on behalf of Ricambigardosi S.r.l.

SEZIONE SECTION	CONTENUTI DELLA SEZIONE SECTION CONTENT	PAGINA PAGE
01	PRESSINI, BASI, MANICI TAMPER, BASES, HANDLES	02
02	TAPPETTINI E SUPPORTI TAMPER MATS AND STANDS	12
03	BATTIFILTRO E CASSETTI KNOCK BOXES AND TAMPING STATIONS	16
04	LATTIERE MILK PITCHERS	22
05	LATTE ART E BARISTA KIT LATTE ART AND BARISTA SET	28
06	MANUTENZIONE E PULIZIA MAINTENANCE AND CLEANING	38
07	PORTAFILTRI SPECIALI SPECIAL PORTAFILTERS	48
08	DOCCE E FILTRI DA COMPETIZIONE COMPETITIONS SHOWERS AND FILTERS	58
09	MACINADOSATORI E MACCHINE DA CAFFE' COFFEE GRINDERS AND COFFE MACHINES	68

# MANICI HANDLES

**[JOEFREX]**<sup>®</sup>  
tools with taste & style

## HANDLE GALAXY



V1202  
Manico in  
silicone rosso  
Red silicone  
handle



V1200  
Manico in  
silicone giallo  
Yellow silicone  
handle



V1203  
Manico in  
silicone crema  
Cream silicone  
handle



V1201  
Manico in  
silicone marrone  
Brown silicone  
handle



V1204  
Manico in  
silicone nero  
Black silicone  
handle

### DESCRIZIONE DESCRIPTION

Manico in silicone con impugnatura ergonomica morbida, compatibile con tutte le basi dei pressini Joe frex  
Tampers Handle, ergonomic design and better grip silicone soft touch Handle. Can be combined with all JoeFrex tampers bases

### DATI TECNICI TECHNIC INFO

Materiale: Silicone, Acciaio	Material: Silicone, Steel
Altezza: 9 cm / 3.5"	Height: 9 cm / 3.5"
Peso: 110g	Weight: 110g

## HANDLE POP



V1206  
Manico in  
alluminio bianco  
White aluminum  
handle



V1205  
Manico in  
alluminio rosso  
Red aluminum  
handle



V1206/N  
Manico in  
alluminio nero  
Black aluminum  
handle

### DESCRIZIONE DESCRIPTION

Manico in alluminio verniciato a polvere per un design ergonomico che garantisce una migliore presa. Compatibile con tutte le basi dei pressini Joe Frex  
Powder-coated aluminum tamper handle for an ergonomic design that guarantee a better grip. Can be combined with all JoeFrex tampers bases

### DATI TECNICI TECHNIC INFO

Materiale: alluminio verniciato a polvere	Material: Powder coated aluminum
Altezza: 7 cm / 2.76"	Height: 7 cm / 2.76"
Peso: 135g	Weight: 135g

## HANDLE ELEGANCE



V1207  
Manico  
color acero  
Maple wood  
handle



V1209  
Manico  
color noce  
Walnut wood  
handle



V1208  
Manico  
color rovere  
Oak wood  
handle

### DESCRIZIONE DESCRIPTION

Manico in legno per un design ergonomico ed elegante. Compatibile con tutte le basi dei pressini Joe Frex  
Wooden tamper handle for an elegant and ergonomic design  
Can be combined with all JoeFrex tampers bases

### DATI TECNICI TECHNIC INFO

Materiale: Legno di quercia	Material: Oak wood
Altezza: 9 cm / 3.54"	Height: 9 cm / 3.54"
Peso: 39g	Weight: 39g



## HANDLE TECHNIC

**[JOEFREX]**<sup>®</sup>  
tools with taste & style



V1210  
Manico argento  
Silver handle



V1212  
Manico Nero  
Black handle



V1211  
Manico rosso  
Red handle

### DESCRIZIONE DESCRIPTION

Il manico Technic con il suo meccanismo di rilascio di precisione integrato consente di impostare in modo affidabile e controllabile la pressione massima, che si desidera per ottenere risultati ottimali ogni volta. Il limitatore di pressione può essere calibrato in un intervallo di 8 kg fino a 21 kg, regolando la vite centrale all'interno della maniglia. Il meccanismo sensibile alla pressione contenuto nel manico dinamometrico in alluminio è realizzato con componenti in acciaio inox.

The handle with its integrated precision release mechanism allows you to reliably set and control the maximal pressure you want for optimal results each time. The pressure limiter can be calibrated within a range of 8 kg to 21 kg (18 lbs to 46 lbs) by adjusting the central screw inside the handle. The dynamometric handle in aluminum have the pressure-sensitive mechanism inside manufactured with stainless steel components.

### DATI TECNICI TECHNIC INFO

Materiale: Alluminio anodizzato Acciaio inox Peso: 260g	Material: Anodized aluminum, stainless steel Weight: 260g
---	---

## 100% MADE IN ITALY

**RICAMBI  
GARDOSI**  
dal 1950



V1105  
Manico in plastica  
Plastic handle

### DESCRIZIONE DESCRIPTION

Manico in materiale plastico made in italy  
Plastic handle made in Italy

### DATI TECNICI TECHNIC INFO

Materiale: Plastica Dimensioni: 8,8cm	Material: Plastic Dimension: 3,46"
---	--



V1106  
Manico in alluminio  
Aluminum handle

### DESCRIZIONE DESCRIPTION

Manico in alluminio made in italy  
Aluminum handle made in Italy

### DATI TECNICI TECHNIC INFO

Materiale: Alluminio Dimensioni: 8,8cm	Material: Aluminum Dimension: 3,46"
--	---



V1106/GHA  
Manico in alluminio trattato  
Treated aluminum handle

### DESCRIZIONE DESCRIPTION

Manico in alluminio trattato al G.H.A, rende la superficie del materiale antibatterica, antiusura e anticorrosione  
Aluminum handle G.H.A treated which provide the material surface anti-bacterial, anti-wear and anti-corrosion properties

### DATI TECNICI TECHNIC INFO

Materiale: Alluminio trattato Dimensioni: 8,8cm	Material: Treated aluminum Dimension: 3,46"
---	---



V1105/LCH  
Manico cubicato legno  
Wood cubic-coated handle

### DESCRIZIONE DESCRIPTION

Manico in materiale plastico cubicato legno  
Plastic handle wood cubic-coated

### DATI TECNICI TECHNIC INFO

Materiale: Plastica, cubatura Dimensioni: 8,8cm	Material: Plastic, cubature Dimension: 3,46"
---	--

# BASI BASES

**[JOEFREX]<sup>®</sup>**  
tools with taste & style



BASE PIANA  
FLAT BASE

V1213 Ø53

V1214 Ø57

V1215 Ø58

BASE CONVESSA  
CONVEX BASE

V1216 Ø53C

V1217 Ø57C

V1218 Ø58C

## DESCRIZIONE DESCRIPTION

Base in acciaio inox compatibile con tutti i manici Joe Frex  
Stainless steel base. Available with all Joe Frex handles

## DATI TECNICI TECHNIC INFO

Materiale: Acciaio inox  
Material: Stainless steel



BASE PIANA  
FLAT BASE

V1219 Ø58

BASE CONVESSA  
CONVEX BASE

V1220 Ø58C

## DESCRIZIONE DESCRIPTION

Base in acciaio inox con anello in silicone che permette di urtare in modo sicuro il bordo del filtro. Compatibili con tutti i manici Joe Frex  
Stainless steel base with silicone ring which enable to touch safely the edge of the filter. Available with all Joe Frex handles

## DATI TECNICI TECHNIC INFO

Materiale: Acciaio inox, Silicone  
Material: Stainless steel, Silicone

**RICAMBI**  
**GARDOSI**

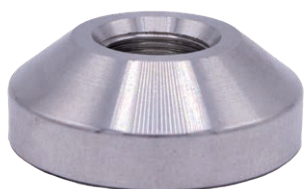

Alluminio Aluminum

V1100/53 Ø 53

V1100/54 Ø 54

V1100/58 Ø 58

## DESCRIZIONE DESCRIPTION

Base in alluminio per una migliore praticità compatibile con i manici Ricambigardosi  
Aluminum base for better praticity compatible with Ricambi Gardosi handles

## DATI TECNICI TECHNIC INFO

Materiale: Alluminio Material: Aluminum

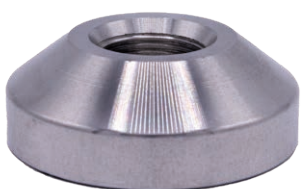

Acciaio inox Stainless steel

V1101/53 Ø 53

V1101/54 Ø 54

V1101/58 Ø 58

## DESCRIZIONE DESCRIPTION

Base in acciaio inox per una maggiore resistenza compatibile con i manici Ricambigardosi  
Aluminum base for better strenght compatible with Ricambi Gardosi handles

## DATI TECNICI TECHNIC INFO

Materiale: Acciaio inox Material: Stainless steel



Alluminio al G.H.A G.H.A. aluminum

V1100/53/GHA Ø 53

V1100/54/GHA Ø 54

V1100/58/GHA Ø 58

## DESCRIZIONE DESCRIPTION

Base in alluminio trattato al G.H.A "Gold Hard Anodizing" che rende la superficie del materiale antibatterica, antiusura e anticorrosione  
Aluminum base G.H.A treated "Gold Hard Anodizing", which provide the material surcace anti-bacterial, anti-wear and anti-corrosion properties

## DATI TECNICI TECHNIC INFO

Materiale: Alluminio al G.H.A  
Material: G.H.A treated aluminum

# PRESSINI COMPLETI COMPLETE TAMPERS



V8140/M0 Ø53  
V011M Ø58

Pressino completo con  
manico in legno marrone  
Complete tamper with  
brown wooden handle

#### DATI TECNICI TECHNIC INFO

Materiale: Legno, Acciaio inox  
Material: Wood, Stainless steel



V8140/B0 Ø53  
V011N Ø58

Pressino completo con  
manico in legno nero  
Complete tamper with  
black wooden handle

#### DATI TECNICI TECHNIC INFO

Materiale: Legno, Acciaio inox  
Material: Wood, Stainless steel



V8140/R0 Ø53  
V8100/R0 Ø58

Pressino piano con  
manico rosso  
Flat tamper with  
red handle

#### DATI TECNICI TECHNIC INFO

Materiale: Legno, Acciaio inox  
Material: Wood, Stainless steel



V011/52 Ø52  
V011/58 Ø58

Pressino in alluminio  
satinato  
Satinated aluminium  
coffee tamper

#### DATI TECNICI TECHNIC INFO

Materiale: Alluminio  
Material: Aluminum



V1470/00  
Pressino in alluminio  
doppio Ø58/53mm  
Aluminum double  
tamper Ø58/53mm

#### DATI TECNICI TECHNIC INFO

Materiale: Alluminio  
Material: Aluminum



V8500/B0 Ø58  
Pressino wave con  
manico in legno nero  
Wave tamper with black  
wooden handle

#### DATI TECNICI TECHNIC INFO

Materiale: Legno, Acciaio inox  
Material: Wood, Stainless steel



V011A Ø58  
Pressino completo  
con manico in alluminio  
Complete tamper  
with aluminum handle

#### DATI TECNICI TECHNIC INFO

Materiale: Alluminio  
Material: Aluminum

# PRESSINI COMPLETI COMPLETE TAMPERS



V012 Ø50 Ø57

Pressino doppio in  
plastica con 2 diametri  
Plastic double tamper  
with 2 diameters

DATI TECNICI TECHNIC INFO

Materiale: Plastica Material: Plastic



V437

Pressino perforatore  
capsule Dolcegusto  
Double tamper piercer  
for Dolce gusto caps

DATI TECNICI TECHNIC INFO

Materiale: Plastica Material: Plastic



V011/53D Ø53

V011/58D Ø58

Pressino dinamometrico  
in acciaio inox  
Stainless steel  
dynamometric tamper

DATI TECNICI TECHNIC INFO

Materiale: Acciaio Inox Material: Stainless steel



V1115/53 Ø53

V1115/54 Ø54

V1115/58 Ø58

Pressino con manico in plastica  
e base in acciaio inox  
Tamper with plastic handle and  
stainless steel base

DATI TECNICI TECHNIC INFO

Materiale: Plastica Material: Plastic  
Materiale: Acciaio Inox Material: Stainless steel



V1110/53 Ø53

V1110/54 Ø54

V1110/58 Ø58

Pressino con manico in plastica  
e base in alluminio  
Tamper with plastic  
handle and aluminum base

DATI TECNICI TECHNIC INFO

Materiale: Plastica Material: Plastic  
Materiale: Alluminio Material: Aluminum



V1130/54 Ø54

V1130/58 Ø58

Pressino con manico in plastica  
e base in alluminio anodizzato  
Tamper with plastic handle and  
anodised aluminum base

DATI TECNICI TECHNIC INFO

Materiale: Plastica Material: Plastic  
Materiale: Alluminio Material: Aluminum



V1116/53 Ø53

V1116/54 Ø54

V1116/58 Ø58

Pressino con manico in alluminio  
e base in acciaio inox  
Tamper with aluminum handle  
and stainless steel base

DATI TECNICI TECHNIC INFO

Materiale: Acciaio inox Material: Stainless steel  
Materiale: Alluminio Material: Aluminum



V1111/53 Ø53

V1111/54 Ø54

V1111/58 Ø58

Pressino con base e  
manico in alluminio  
Tamper with aluminum  
handle and base

DATI TECNICI TECHNIC INFO

Materiale: Alluminio Material: Aluminum

# PRESSINI COMPLETI COMPLETE TAMPERS



V1101/53/LCH Ø53  
V1101/54/LCH Ø54  
V1101/58/LCH Ø58

Pressino con manico effetto legno e base in acciaio inox  
Tamper with Wood cubic-coated handle and stainless steel base

#### DATI TECNICI TECHNIC INFO

Materiale: Plastica Material: Plastic  
Materiale: Acciaio Inox Material: Stainless Steel



V1100/53/LCH Ø53  
V1100/54/LCH Ø54  
V1100/58/LCH Ø58

Pressino con manico effetto legno e base in alluminio  
Tamper with Wood cubic-coated handle and aluminum base

#### DATI TECNICI TECHNIC INFO

Materiale: Plastica Material: Plastic  
Materiale: Aluminum Material: Aluminum



V1104/53/LCH Ø53  
V1104/54/LCH Ø54  
V1104/58/LCH Ø58

Pressino con manico effetto legno e base in alluminio anodizzato  
Tamper with Wood cubic-coated handle and anodised aluminum base

#### DATI TECNICI TECHNIC INFO

Materiale: Plastica Material: Plastic  
Materiale: Aluminum Material: Aluminum



V1117/53/L/GHA Ø53  
V1117/54/L/GHA Ø54  
V1117/58/L/GHA Ø58

Pressino con manico effetto legno e base in alluminio al GHA  
Tamper with Wood cubic-coated handle and GHA aluminum base

#### DATI TECNICI TECHNIC INFO

Materiale: Plastica Material: Plastic  
Materiale: Aluminum Material: Aluminum



V1111/53/GHA Ø53  
V1111/54/GHA Ø54  
V1111/58/GHA Ø58

Pressino con manico e base in alluminio trattato al GHA  
Tamper with handle and GHA aluminum base

#### DATI TECNICI TECHNIC INFO

Materiale: Alluminio al GHA  
Material: G.H.A Aluminum



V417

Pressino perforatore capsule Lavazza blue/a modo mio  
Tamper piercer for Lavazza blue/a modo mio capsules

#### DATI TECNICI TECHNIC INFO

Materiale: Alluminio Material: Aluminum

## PIANA CAFFÈ' LEVELING TOOL



V8353/53 Ø53 V8350/58 Ø58  
V8357/57 Ø57 V8350/585 Ø58,5

Pianacaffè in acciaio inox  
Stainless steel coffee leveling tool

#### DATI TECNICI TECHNIC INFO

Materiale: Acciaio Inox Material: Stainless steel

V8350/58/L Ø58

Pianacaffè in acciaio inox e legno  
Stainless steel and wood coffee leveling tool

#### DATI TECNICI TECHNIC INFO

Materiale: Acciaio Inox Material: Stainless steel



# PRESSINI COMPLETI COMPLETE TAMPERS

	<u>Ø53</u>	<u>Ø57</u>	<u>Ø58</u>
Astoria cts05 P4Y	○		
Astoria cts03			○
Aurora brugnetti			○
Bezzera			○
Bfc-Royal			○
Brasilia			○
Carimali			○
Casadio			○
Cimbali			○
Conti Sacome			○
Elektra			○
Faema			○
Gaggia			○
Grimac			○
Fiorenzato			○
Iberital		○	
Marzocco			○
Nuova Simonelli			○
La Pavoni			○
Rancilio		○	○
San Marco	○		
Sanremo		○	○
La Spaziale	○		
Vibiemme		○	○
Victoria Arduino		○	○
Wega			○
Wega Concept	○		

# TAPPETINI TAMPER MATS

V1221

Tappetino angolare nero  
Black corner tamping mat



DESCRIZIONE DESCRIPTION

Tappetino angolare di 5mm di spessore, sollevato di 8mm in tutto il bordo per garantire più stabilità e protezione per le superfici  
Corner tamping features 5mm thick silicone which is raised to a full 8mm around the rim to ensure more stability and surface protection

DATI TECNICI TECHNIC INFO

Materiale: Silicone  
Material: Silicone

Dimensioni: 15 x 20 x 4.5cm  
Dimensions: 5.9" x 7.87" x 1.77"

V1222/R V1222/N

Poggiafiltro angolare  
Silicone tamping mat



DESCRIZIONE DESCRIPTION

Il più piccolo tra i poggiafiltro completamente in silicone alimentare di 10mm di spessore e 146g di peso. Lavabile in lavastoviglie  
The smallest tamping mats completely in food-grade silicone 10mm thick and 146g in weight. Dishwasher safe

DATI TECNICI TECHNIC INFO

Materiale: Silicone  
Material: Silicone

Dimensioni: 18.5 x 12 x 3.9cm  
Dimensions: 7.28" x 4.72" x 1.53"

V1221/1

Tappetino angolare nero con sagoma portafiltro  
Black corner tamping mat with overhang



DESCRIZIONE DESCRIPTION

Tappetino angolare adattabile a qualsiasi superficie con sagomatura per appoggiare il portafiltro così da garantire una perfetta pressione del caffè  
Corner mat adaptable to any surface with shape to support the filter holder so as to ensure a perfect coffee pressure

DATI TECNICI TECHNIC INFO

Materiale: Silicone  
Material: Silicone

Dimensioni: 21 x 15 x 4.4cm  
Dimensions: 8.26" x 5.9" x 1.73"

V1221/2

Tappetino angolare nero con sagoma portafiltro  
Black corner tamping mat with overhang



DESCRIZIONE DESCRIPTION

Tappetino angolare con doppia sede per pressino e sagomatura per appoggiare il portafiltro garantendo una perfetta pressione del caffè  
Corner mat with double tamper seat and shape to support the filter holder so as to ensure a perfect pressure on coffee

DATI TECNICI TECHNIC INFO

Materiale: Silicone  
Material: Silicone

Dimensioni: 20.5 x 15 x 5cm  
Dimensions: 8.07" x 5.9" x 1.96"

V0275/00

Tappetino angolare nero sagomato a forma di gatto  
Black corner tamping mat cat shaped



DESCRIZIONE DESCRIPTION

Tappetino angolare sagomato a forma di gatto con sagomatura per appoggiare il portafiltro garantendo una perfetta pressione del caffè  
Corner mat cat formed and shaped to support the filter and guarantee perfect coffee pressure

DATI TECNICI TECHNIC INFO

Materiale: Silicone  
Material: Silicone

Dimensioni: 21 x 14cm  
Dimensions: 8.2" x 5.5"

V0265/00

Tappetino angolare nero con sagoma portapressino  
Black corner tamping mat with tamper holder



DESCRIZIONE DESCRIPTION

Tappetino angolare con sede per pressino, ideale per appoggiare il portafiltro garantendo una perfetta pressione del caffè  
Corner mat with tamper seat, ideal for support the filter holder so as to ensure a perfect pressure on coffee

DATI TECNICI TECHNIC INFO

Materiale: Silicone  
Material: Silicone

Dimensioni: 24 x 16cm  
Dimensions: 9.4" x 6.3"



V1223

Poggiafiltro professionale con aggancio per tavolo  
Professional tamper station with table attachment

DESCRIZIONE DESCRIPTION

Poggiafiltro professionale con aggancio per tavolo per un'ottima stabilità e praticità di lavoro  
Professional tamper station with table attachment for excellent stability and practicality of work

DATI TECNICI TECHNIC INFO

Materiale: Alluminio, Silicone  
Material: Aluminum, Silicone  
Dimensioni: 20 x 9 x 7cm  
Dimensions: 7.87" x 3.54" x 2.75"



V1224

Poggiafiltro nero  
Black tamper station

DESCRIZIONE DESCRIPTION

Pratico poggiafiltro in silicone e alluminio con sede per pressino che garantisce versatilità e velocità di lavoro

Practical silicone and aluminum tamper station with tamper seat that guarantees versatility and working speed

V1225

Poggiafiltro rosso  
Red tamper station

V1226

Poggiafiltro bianco  
White tamper station

DATI TECNICI TECHNIC INFO

Materiale: Alluminio, Silicone  
Material: Aluminum, Silicone  
Dimensioni: 18.5 x 12 x 3.9cm  
Dimensions: 7.28" x 4.72" x 1.53"



V092

Appoggia pressino  
Tamper support

DATI TECNICI TECHNIC INFO

Materiale: Acciaio inox  
Material: Stainless steel



V322

Poggiafiltro e pressino  
Tamper and filter support

DATI TECNICI TECHNIC INFO

Materiale: Silicone, Acciaio inox  
Material: Silicone, Stainless steel  
Dimensioni: 18.5 x 12 x 3.9cm  
Dimensions: 7.28" x 4.72" x 1.53"



V323

Poggiafiltro  
Tamping station

DATI TECNICI TECHNIC INFO

Materiale: Alluminio  
Material: Aluminum



V1136

Tappetino in silicone nero  
Black silicone tamping mat

DATI TECNICI TECHNIC INFO

Materiale: Silicone  
Material: Silicone  
Dimensioni: 18.5 x 12 x 3.9cm  
Dimensions: 7.28" x 4.72" x 1.53"



V323C

Poggiafiltro con piedini  
Tamping station with foot

DATI TECNICI TECHNIC INFO

Materiale: Acciaio inox  
Material: Stainless steel  
Dimensioni: 18.5 x 12 x 3.9cm  
Dimensions: 7.28" x 4.72" x 1.53"



V1227

Set completo barista composto da:  
Complete barista set composed by:

V1136

Tappetino in silicone nero  
Black silicon tamping mat

V323C

Poggiafiltro in alluminio con piedini  
Aluminum tamping station with foot

V1110/58

Pressino con manico in plastica e base in alluminio  
Complete tamper with plastic handle and aluminum base

# BATTIFILTRO KNOCK BOX

**[JOE FREX]<sup>®</sup>**  
tools with taste & style



V1228

Battifiltro rosso in alluminio  
con barra in silicone  
Red aluminum knock box  
and silicone bar



V1229

Battifiltro grigio in alluminio  
con barra in silicone  
Gray aluminum knock box  
and silicone bar



V1230

Battifiltro nero in alluminio  
con barra in silicone  
Black aluminum knock box  
and silicone bar

## DESCRIZIONE DESCRIPTION

Battifiltro con anello in silicone alla base  
per una buona stabilità e protezione  
delle superfici.

Filter beat with silicone ring at the  
base for good surface stability and  
protection.

## DATI TECNICI TECHNIC INFO

Materiale: Silicone, Alluminio  
Material: Silicone, Aluminum

**M.M. METALLURGICA**  
**MOTTA<sup>®</sup>**



V321

Battifiltro in acciaio inox e  
barra silicone  
Stainless steel knock box  
and silicone bar



V7750/00

Battifiltro domestico in acciaio inox  
e barra silicone  
Stainless steel knock box  
and silicone bar



V3100

Battifiltro in acciaio inox e  
barra silicone  
Stainless steel knock box  
and silicone bar

## DESCRIZIONE DESCRIPTION

Battifiltro in acciaio inox con rivestimento  
in gomma sul bordo e sul fondo per una  
buona stabilità e protezione delle superfici.  
Stainless steel filter beat with rubber  
coating on the edge and bottom for good  
stability and surface protection.

## DATI TECNICI TECHNIC INFO

Materiale: Silicone, Acciaio inox  
Material: Silicone, Stainless steel



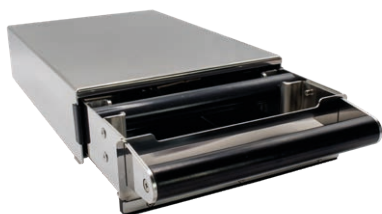

V1232  
 21cm → Cassetto batti e raccogli  
 ↓8cm fondi professionale  
 31cm ↙ Professional knock box  
 drawer

DATI TECNICI    TECHNIC INFO

Dimensioni: 21 x 10 x 8cm  
 Dimensions: 8.27" x 12.25" x 3.15"  
 Peso: 3.5kg  
 Weight: 11lb

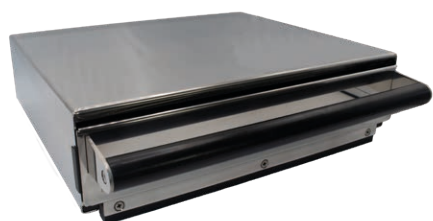

V1231  
 36cm → Cassetto batti e raccogli  
 ↓11cm fondi professionale  
 30cm ↙ Professional knock box  
 drawer

DATI TECNICI    TECHNIC INFO

Dimensioni: 36 x 30 x 11cm  
 Dimensions: 14.17" x 11.81" x 4.33"  
 Peso: 3.5kg  
 Weight: 11lb



V1233  
 20cm → Cassetto batti e raccogli  
 ↓11cm fondi professionale  
 30cm ↙ Professional knock box  
 drawer

DATI TECNICI    TECHNIC INFO

Dimensioni: 20 x 30 x 11cm  
 Dimensions: 7.87" x 11.81" x 4.33"  
 Peso: 4.4kg  
 Weight: 11lb



V1234  
 23cm → Cassetto batti e raccogli  
 ↓11cm fondi professionale  
 30cm ↙ Professional knock box  
 drawer

DATI TECNICI    TECHNIC INFO

Dimensioni: 23 x 30 x 11cm  
 Dimensions: 9.06" x 11.81" x 4.33"  
 Peso: 5kg  
 Weight: 11lb

V1235  
 23cm → Cassetto batti e raccogli  
 ↓11cm fondi professionale  
 40cm ↙ Professional knock box  
 drawer

DATI TECNICI    TECHNIC INFO

Dimensioni: 23 x 40 x 11cm  
 Dimensions: 9.06" x 15.75" x 4.33"  
 Peso: 7kg  
 Weight: 15.4lb

V1236  
 28cm → Cassetto batti e raccogli  
 ↓11cm fondi professionale  
 37cm ↙ Professional knock box  
 drawer

DATI TECNICI    TECHNIC INFO

Dimensioni: 28 x 37 x 11cm  
 Dimensions: 11.02" x 14.57" x 4.33"  
 Peso: 8.2kg  
 Weight: 17.6lb

V1237  
 32cm → Cassetto batti e raccogli  
 ↓11cm fondi professionale  
 45cm ↙ Professional knock box  
 drawer

DATI TECNICI    TECHNIC INFO

Dimensioni: 32 x 45 x 11cm  
 Dimensions: 12.60" x 17.72" x 4.33"  
 Peso: 8.2kg  
 Weight: 17.6lb



# CASSETTI DRAWER BASES

**[JOEFREX]<sup>®</sup>**  
tools with taste & style



**V1238**  
 13cm → Cassetto batti  
 ↓8cm e raccogli fondi  
 22cm ↙ Knock box drawer

## DATI TECNICI TECHNICAL INFO

Dimensioni: 13 x 22 x 8cm  
 Dimensions: 5.12" x 8.66" x 3.15"  
 Peso: 1.4kg  
 Weight: 2.5lb



**V1239**  
 19.5cm → Cassetto batti  
 ↓9cm e raccogli fondi  
 27cm ↙ Knock box drawer

## DATI TECNICI TECHNICAL INFO

Dimensioni: 19.5 x 27 x 9cm  
 Dimensions: 7.68" x 10.63" x 3.54"  
 Peso: 2kg  
 Weight: 5lb



**V1240**  
 27cm → Cassetto batti  
 ↓9cm e raccogli fondi  
 30cm ↙ Knock box drawer

## DATI TECNICI TECHNICAL INFO

Dimensioni: 27 x 30 x 9cm  
 Dimensions: 10.63" x 11.81" x 3.54"  
 Peso: 2.9kg  
 Weight: 7lb

## DESCRIZIONE DESCRIPTION

Cassetto batti e raccogli fondi in acciaio inox con barra in silicone alimentare per attutire gli urti. Ideato per la casa, con il suo aspetto decorativo è ideale per i piccoli macinadosatori.  
 Stainless steel knock box drawer with food grade silicone bar that reduces bumps. Designed for home with his decorative appearance is ideal for small grinders.

## DATI TECNICI TECHNICAL INFO

Materiale: Silicone, Acciaio inox  
 Material: Silicone, Stainless steel



**V1241**  
 33cm → Cassetto a incasso  
 ↓8cm batti e raccogli fondi  
 30cm ↙ Open knock-out  
 chute

## DESCRIZIONE DESCRIPTION

Cassetto batti e raccogli fondi ad incasso, con struttura portagruppo integrata in silicone. Può essere installata su un tavolo o su un piano di lavoro collocando al di sotto un contenitore dei rifiuti per raccogliere direttamente i fondi.  
 Open knock-out chute, combined with an integrated tamping station in food grade silicone. It can be installed into a table or worktop by placing below a box.

## DATI TECNICI TECHNICAL INFO

Materiale: Silicone, Acciaio inox  
 Material: Silicone, Stainless steel  
 Dimensioni: 33 x 30 x 8cm  
 Dimensions: 13" x 12" x 3.2"  
 Dimensioni sede: 304 x 196mm  
 Cut-out size: 11.97" x 7.72"

# LATTIERE MILK PITCHERS

---

**[JOE FREX]**<sup>®</sup>  
tools with taste & style



V1242  
Lattiera 350ml  
in acciaio inox 18/10  
18/10 Stainless steel  
Milk pitcher 350ml



V1243  
Lattiera 590ml  
in acciaio inox 18/10  
18/10 Stainless steel  
Milk pitcher 590ml



V1244  
Lattiera 950ml  
in acciaio inox 18/10  
18/10 Stainless steel  
Milk pitcher 950ml



V1245  
Lattiera 1400ml  
in acciaio inox 18/10  
18/10 Stainless steel  
Milk pitcher 1400ml



V1246  
Lattiera 90ml  
Milk pitcher 90ml



V1247  
Lattiera 590ml per  
riempimento a goccia  
Milk pitcher 590ml for  
drip filling

---

## DESCRIZIONE DESCRIPTION

Lattiere professionali in acciaio inox 18/10 di alta qualità, disponibili in diverse misure per ogni genere di necessità. Dotato di beccuccio ideale anche per Latte art. Professional milk pitcher made in high quality stainless steel 18/10, available in different sizes for every kind of need. Also ideal for Latte art.

---

## DATI TECNICI TECHNIC INFO

Materiale: Acciaio inox  
Material: Stainless steel

# LATTIERE MILK PITCHERS

**[JOEFREX]**<sup>®</sup>  
tools with taste & style



V1248  
Lattiera 350ml  
Milk pitcher 350ml

V1249  
Lattiera 590ml  
Milk pitcher 590ml



V1250  
Lattiera 350ml  
Milk pitcher 350ml

V1251  
Lattiera 590ml  
Milk pitcher 590ml



V1252  
Lattiera 350ml  
Milk pitcher 350ml

V1253  
Lattiera 590ml  
Milk pitcher 590ml

## DESCRIZIONE DESCRIPTION

Lattiere professionali in acciaio inox di alta qualità, con incisione per evitare contaminazione del latte. Dotate di beccuccio Ideale anche per Latte art. Disponibili in diverse misure.

High-quality stainless steel milk pitcher with engraving to avoid milk contamination ideal spout for latte art. Available in different sizes.

## DATI TECNICI TECHNIC INFO

Materiale: Acciaio inox  
Material: Stainless steel



V1258  
Lattiera 350ml  
Milk pitcher 350ml

V1259  
Lattiera 590ml  
Milk pitcher 590ml



V1260  
Lattiera 350ml  
Milk pitcher 350ml

V1261  
Lattiera 590ml  
Milk pitcher 590ml



V1262  
Lattiera 350ml  
Milk pitcher 350ml

V1263  
Lattiera 590ml  
Milk pitcher 590ml



V1264  
Lattiera 350ml  
Milk pitcher 350ml

V1265  
Lattiera 590ml  
Milk pitcher 590ml

## DESCRIZIONE DESCRIPTION

Lattiere professionali in acciaio inox 18/10 di alta qualità verniciato a polvere. Disponibili in diverse misure per ogni genere di necessità. Dotato di beccuccio Ideale anche per Latte art.

Professional milk pitcher made in high quality stainless steel 18/10 and powder coated, available in different sizes for every kind of need. Also ideal for Latte art.

## DATI TECNICI TECHNIC INFO

Materiale: Acciaio inox, vernice a polvere  
Material: Stainless steel, powder coating

# LATTIERE MILK PITCHERS



V0901/150  
Lattiera 150ml  
Milk pitcher 150ml



V0901/25  
Lattiera 250ml  
Milk pitcher 250ml



V0901/35  
Lattiera 350ml  
Milk pitcher 350ml



V099/50  
Lattiera 500ml  
Milk pitcher 500ml



V093/75  
Lattiera 750ml  
Milk pitcher 750ml



V097/100  
Lattiera 1000ml  
Milk pitcher 1000ml

## DESCRIZIONE DESCRIPTION

Lattiere professionali in acciaio inox di alta qualità, disponibili in diverse misure per ogni genere di necessità. Dotato di beccuccio Ideale anche per Latte art. Professional milk pitcher made in high quality stainless steel, available in different sizes for every kind of need. Also ideal for Latte art.

## DATI TECNICI TECHNIC INFO

Materiale: Acciaio inox  
Material: Stainless steel



V098  
Lattiera 250ml  
Milk pitcher 250ml



V099  
Lattiera 500ml  
Milk pitcher 500ml



V093  
Lattiera 750ml  
Milk pitcher 750ml



V097  
Lattiera 1000ml  
Milk pitcher 1000ml

## DESCRIZIONE DESCRIPTION

Lattiere in acciaio inox di alta qualità, dotato di beccuccio Ideale anche per Latte art. Perfette per un buon cappuccino anche a casa. Disponibili in diverse misure per ogni genere di necessità. Milk pitcher made in high quality stainless steel, fitted with spout also ideal for Latte art. Perfect for a good cappuccino even at home. Available in different sizes for every kind of need.

## DATI TECNICI TECHNIC INFO

Materiale: Acciaio inox  
Material: Stainless steel

# LATTIERE MILK PITCHERS



V560/35B  
Lattiera bianca 350ml  
White milk pitcher 350ml

V560/50B  
Lattiera bianca 500ml  
White milk pitcher 500ml

V560/75B  
Lattiera bianca 750ml  
White milk pitcher 750ml



V598/35R  
Lattiera rossa 350ml  
Red milk pitcher 350ml

V598/50R  
Lattiera rossa 500ml  
Red milk pitcher 500ml

V598/75R  
Lattiera rossa 750ml  
Red milk pitcher 750ml



V599/35N  
Lattiera nera 350ml  
Black milk pitcher 350ml

V599/50N  
Lattiera nera 500ml  
Black milk pitcher 500ml

V599/75N  
Lattiera nera 750ml  
Black milk pitcher 750ml



V02835/00  
Lattiera verde 350ml  
Green milk pitcher 350ml

V02850/00  
Lattiera verde 500ml  
Green milk pitcher 500ml

V02875/00  
Lattiera verde 750ml  
Green milk pitcher 750ml



V2635/00  
Lattiera arancione 350ml  
Orange milk pitcher 350ml

V2650/00  
Lattiera arancione 500ml  
Orange milk pitcher 500ml

V2675/00  
Lattiera arancione 750ml  
Orange milk pitcher 750ml

## DESCRIZIONE DESCRIPTION

Lattiere professionali in acciaio inox di alta qualità e verniciato a polvere. Disponibili in diverse misure per ogni genere di necessità. Dotato di beccuccio ideale anche per Latte art.

Professional milk pitcher made in high quality stainless steel and powder coated, available in different sizes for every kind of need. Also ideal for Latte art.

## DATI TECNICI TECHNIC INFO

Materiale: Acciaio inox  
Material: Stainless steel



V599/35N  
Lattiera in acciaio  
inox 350ml  
Stainless steel milk  
pitcher 350ml



V599/35N  
Lattiera blu 350ml  
Blue milk pitcher 350ml



V0015/00  
Cremierino 70ml  
Cream Jug 70ml



# LATTE ART LATTE ART

## PENNE PER LATTE ART LATTE ART PENS

**[JOEFREX]**<sup>®</sup>  
tools with taste & style



V1269  
Kit completo di 3 penne per latte art  
Complete latte art set with 3 latte tools

COMPOSTO DA  
COMPOSED BY



V1266  
Penna-cucchiaio per latte art  
Latte art Spoon-Lance



V1267  
Penna-gancio per latte art  
Latte art Knob-Hook



V1268  
Penna-spatola per latte art  
Latte art Spatula-Spike



V1270  
Penna-cucchiaio per latte art  
Latte art pen with Spatula-Spike

### DESCRIZIONE DESCRIPTION

Set di penne per latte art, in alluminio lucidato e rivestito in silicone, ideale per decorare la schiuma del latte nei caffè e cappuccini. Set composto da 3 penne:  
Penna-cucchiaio  
Penna-gancio  
Penna-spatola  
Complete latte art set in polished aluminum and silicone handle. Great for decorating the milk froth on your coffee and cappuccino  
Set composed by 3 pens  
Spoon-lance  
Knob-hook  
Spatula-spike

### DATI TECNICI TECHNIC INFO

Materiale: Alluminio, silicone  
Material: Aluminum, silicone

### DESCRIZIONE DESCRIPTION

Penna-cucchiaio per latte art in alluminio lucidato  
Latte art pen with spoon and spike made in polished aluminum

### DATI TECNICI TECHNIC INFO

Materiale: Alluminio  
Material: Aluminum

## SPARGITORI DISPENSERS

**M.M. METALLURGICA**  
**MOTTA**<sup>®</sup>



V094  
Spargi zucchero  
Sugar dispenser



V094C  
Spargi cacao  
Cocoa dispenser

### DESCRIZIONE DESCRIPTION

Contenitori spargicacao e spargizucchero in acciaio inox  
Stainless steel cocoa and sugar dispenser

### DATI TECNICI TECHNIC INFO

Materiale: Acciaio inox 18/10  
Material: Stainless steel 18/10

## CUCCHIAI SPOONS

**M.M. METALLURGICA**  
**MOTTA**<sup>®</sup>



V0198/00S6  
Set cucchiaini per cappuccino 6pz  
Cappuccino spoons set 6 pcs



V0482/00  
Cucchiaio da assaggio  
Tasting spoon



V0200/00S6  
Set cucchiaini per latte macchiato 6pz  
Latte macchiato spoons set 6 pcs



V1280  
 Barista kit Napoli  
 Set di attrezzatura da bar  
 100% made in Italy  
 Napoli barista kit  
 Set of bar equipment  
 100% made in Italy

COMPOSTO DA COMPOSED BY

Lattiera 50ml	50ml milk jug
Pressino Ø58 manico nero	Complete tamper Ø58 black handle
Termometro	Thermometer
Cucchiaino	Spoon
Spazzolino	Brush



V1281  
 Barista kit Torino  
 Set di attrezzatura da bar  
 100% made in Italy  
 Torino barista kit  
 Set of bar equipment  
 100% made in Italy

COMPOSTO DA COMPOSED BY

Lattiera 75ml	75ml milk jug
Pressino Ø58 manico alluminio	Complete tamper Ø58 aluminum handle
Termometro	Thermometer
Spargi cacao	Cocoa dispenser



V1282  
 Barista kit Milano  
 Set di attrezzatura da bar  
 100% made in Italy  
 Milano barista kit  
 Set of bar equipment  
 100% made in Italy

COMPOSTO DA COMPOSED BY

Lattiera 35ml	35ml milk jug
Pressino Ø58 manico legno	Complete tamper Ø58 wooden handle
Termometro	Thermometer
Lattiera 50ml	50ml milk jug
Poggiapressino	Tamper support
Spargicacao	Cocoa dispenser
Penna per latte art	Latte art pen



V1283  
 Barista kit Firenze  
 Set di attrezzatura da bar  
 100% made in Italy  
 Firenze barista kit  
 Set of bar equipment  
 100% made in Italy

COMPOSTO DA COMPOSED BY

Lattiera 15ml	15ml milk jug
Pressino Ø58 alluminio	Aluminum complete tamper Ø58
Lattiera 75ml	75ml milk jug
Spargicacao	Cocoa dispenser
Termometro	Thermometer



V1284  
 Barista kit Venezia  
 Set di attrezzatura da bar  
 100% made in Italy  
 Venezia barista kit  
 Set of bar equipment  
 100% made in Italy

COMPOSTO DA COMPOSED BY

Lattiera 50ml	50ml milk jug
Termometro	Thermometer
Lattiera 35ml	35ml milk jug
Pressino Ø58 alluminio	Aluminum complete tamper Ø58



V1285  
 Barista kit Roma  
 Set di attrezzatura da bar  
 100% made in Italy  
 Roma barista kit  
 Set of bar equipment  
 100% made in Italy

COMPOSTO DA COMPOSED BY

Lattiera 50ml	50ml milk jug
Pressino Ø58 manico legno	Complete tamper Ø58 wooden handle
Termometro	Thermometer
Lattiera 75ml	75ml milk jug
Poggiapressino	Tamper support
Spargicacao	Cocoa dispenser
Penna per latte art	Latte art pen

# BARISTA KIT BARISTA SET

## BICCHIERINI GRADUATI GRADUATED GLASSES



V1277  
Espresso shot in  
vetro 60ml  
60ml glass  
espresso shot



V1277/1  
Bicchiere graduato  
in vetro 60ml  
60ml graduated  
glass



V1278  
Bicchiere graduato  
in vetro 45ml  
45ml graduated  
glass



V1279  
Bicchiere graduato  
in vetro 30ml  
30ml graduated  
glass



V559  
Bicchiere graduato  
conico in plastica 60ml  
60ml plastic graduated  
conical glass

## TOVAGLIETTE AL G.H.A® G.H.A PLACEMATS®



G.H.A.® "Golden Hard Anodizing" il quale consiste nella realizzazione di una speciale ossidazione dura o semidura dell'alluminio, con sigillatura agli ioni d'Argento, che uniscono alle già ottime caratteristiche dell'ossido di alluminio le particolari proprietà del nobile metallo, rendendo la superficie trattata antibatterica, antiusura e anticorrosione.

innovative patent called G.H.A. "Golden Hard Anodizing", which consists of the realization of the special hard or semi-hard aluminum oxidation with the addition of silver ions, combining the excellent properties of aluminum oxide produced by the company and the particular properties of Silver rendering the surface antibacterial, anti corrosion and anti wear.



SLVTOP3040G  
Tappetino in G.H.A  
30 x 40 oro serigrafato  
"Omone del caffè"  
Golden placemat in G.H.A  
30 x 40 silk-screened  
"Omone del caffè"



SLVTOP2030  
Tappetino in G.H.A  
20 x 30 oro serigrafato  
"Omone del caffè"  
Golden placemat in G.H.A  
20 x 30 silk-screened  
"Omone del caffè"

## VASSOI AL G.H.A® G.H.A TRAYS®



SLVKS3040G  
Vassoio in G.H.A  
30 x 40 oro serigrafato  
"Omone del caffè"  
Golden placemat in G.H.A  
30 x 40 silk-screened  
"Omone del caffè"



SLVKS2030G  
Food tray in G.H.A  
20 x 30 oro serigrafato  
"Omone del caffè"  
Golden placemat in G.H.A  
20 x 30 silk-screened  
"Omone del caffè"



## V1448

Grebiule Bologna  
Bologna Apron

PERSONALIZZABILE CON LOGO RICAMATO  
CUSTOMIZABLE WITH EMBROIDERED LOGO

### DESCRIZIONE DESCRIPTION

Grebiule con pettorina realizzato in dacron, un tessuto antipiega resistente, leggero e pratico da pulire. Lacci in vita da legare sulla schiena. Dotato di una tasca e girocollo regolabile mediante nastro. Colore bordeaux con cuciture a contrasto e dettaglio in ottone anticato.

Apron with bib made of Dacron, a resistant anti-fold fabric, light and practical to clean. Features one pocket and ribbon-adjustable neckline. Bordeaux color with contrast stitching and antiqued brass detail.

### DATI TECNICI TECHNIC INFO

100% Dacron, Taglia unica Made in Italy  
100% Dacron, single size Made in Italy  
70 x 83cm



## V1449

Grebiule Milano  
Milano Apron

PERSONALIZZABILE CON LOGO RICAMATO  
CUSTOMIZABLE WITH EMBROIDERED LOGO

### DESCRIZIONE DESCRIPTION

Grebiule in denim con pettorina. Allacciatura regolabile con lacci ad incrocio sulla schiena per distribuire meglio il peso e offrire una vestibilit  confortevole, ideale per utilizzi prolungati. Colore grigio con tasche a contrasto e dettagli in ottone anticato.

Denim apron with bib. Adjustable cross-over lace-up fastening at the back for better weight distribution and a comfortable fit, perfect for extended use. Gray color with contrasting pockets and antiqued brass details.

### DATI TECNICI TECHNIC INFO

100% cotone, Taglia unica Made in Italy  
100% cotton, single size Made in Italy  
73,5 x 82,5cm



## V1450

Grebiule Palermo  
Palermo Apron

PERSONALIZZABILE CON LOGO RICAMATO  
CUSTOMIZABLE WITH EMBROIDERED LOGO

### DESCRIZIONE DESCRIPTION

Grebiule in denim con pettorina, lacci in vita da legare sulla schiena e ampia tasca frontale divisa in due parti. Allacciatura al collo e in vita regolabile attraverso bottoni a pressione. Colore caff  con cuciture a contrasto e dettagli in ottone anticato.

Denim apron with bib, waist ties to be crossed at the back and large front pocket divided in two parts. Fastening at neck and waist adjustable through snap buttons. Coffee-colored with contrast stitching and antiqued brass details.

### DATI TECNICI TECHNIC INFO

100% cotone, Taglia unica Made in Italy  
100% cotton, single size Made in Italy  
70 x 83cm

# BARISTA KIT BARISTA SET

## TOOL BAG

**[JOEFREX]**<sup>®</sup>  
tools with taste & style



V1274  
Barista tool bag nera  
Black barista tool bag

V1273  
Barista tool bag marrone  
Brown barista tool bag

### DESCRIZIONE DESCRIPTION

Barista Tool bag è disponibile in colorazione nera o marrone, realizzata in microfibra fornisce un modo perfetto per portare i propri strumenti da barista, come lattiere accessori ecc.  
Barista tool bag is AVAILABLE in black or brown. The bag is made in microfiber and provide a perfect way to carry our barista tools like milk jug, tamper etc.



### DATI TECNICI TECHNIC INFO

Materiale: Microfibra Material: Microfiber	Dimensioni: 25 x 22 x 9cm Dimension: 9.8" x 8.6" x 3.5"	Tool bag venduta vuota Tool bag is sold empty
---	--	--

## CAPPUCCINATORI MILK FROTHER



MG377N  
MG377  
Cappuccinatore modello Saeco  
Black milk frother model Saeco



SAE745  
Pannarello snodo 90° acciaio per Grimac Saeco  
90° joint steel pannarello Grimac Saeco

## CUCCHIAI DOSATORI MEASURING SPOON



V006  
Cucchiaino dosatore 7gr in acciaio inox  
Stainless steel 7gr measuring spoon



V006/1  
Cucchiaino dosatore 7gr in plastica  
Plastic 7gr measuring spoon

## BARISTA KEY



V4800/00  
Chiave universale in acciaio inox  
Stainless steel universal key





## V131

Bilancia elettronica TANITA 1479V

Electronic scale TANITA 1479V

### DESCRIZIONE DESCRIPTION

Bilancia digitale ad alta precisione perfetta per misurare le dosi di caffè  
High precision digital espresso scale, perfect for measuring coffee

### DATI TECNICI TECHNIC INFO

Materiale: Plastica	Max capacità: 120g	Accuratezza: 0.1g	Dimensioni: 7.6 x 15.5cm
Material: Plastic	Max capacity: 120g	Accuracy: 0.1g	Material: 3" x 6.1"



## V131/5

Bilancia elettronica MINI II

Electronic scale MINI II

### DESCRIZIONE DESCRIPTION

Bilancia digitale ad alta precisione perfetta per misurare le dosi di caffè  
High precision digital espresso scale, perfect for measuring coffee

### DATI TECNICI TECHNIC INFO

Materiale: Plastica	Max capacità: 600g	Accuratezza: 0.1g
Material: Plastic	Max capacity: 600g	Accuracy: 0.1

**[JOE FREX]<sup>®</sup>**  
tools with taste & style



## V1290

Bilancia elettronica 2 Batterie incluse (AAA)

Electronic scale 2 (AAA) Included batteries

### DESCRIZIONE DESCRIPTION

Bilancia digitale perfetta per misurare dosi da 7 o 14g  
Digital espresso scale, perfect for measuring coffee 7 or 14g

### DATI TECNICI TECHNIC INFO

Materiale: Plastica, Acciaio inox	Max capacità: 500g	Accuratezza: 0.01g
Material: Plastic, Stainless steel	Max capacity: 500g	Accuracy: 0.01g
Dimensioni: 10 x 26 x 2cm		
Material: 3 1/8" x 4 1/4" x 3/4"		

## acaia

Le bilance ACAIA sono uniche nel loro genere. Fabbricate con materiali di altissima qualità, offrono praticità ed una grandissima accuratezza. La bilancia ACAIA è dotata di un'ampia suite di applicazioni per diversi usi e numerose funzionalità indispensabili per il barista professionista.

ACAIA scales are unique. Made of the highest quality materials and "laboratory parts", offering convenience and high accuracy. ACAIA scales have a wide suite of applications for different uses and numerous essential features for professional barista.

### ACAIA PEARL

V1291



Modalità di pesatura  
Weighing mode



Modalità timer  
Timer mode

V1292



Auto tara  
Auto tare mode



Avvio automatico timer  
Timer auto start



Modalità espresso  
Espresso mode



Modalità bevanda  
Beverage mode

#### DATI TECNICI | TECHNIC INFO

Materiale: Policarbonato  
Material: Polycarbonate

Dimensioni: 160mm x 160mm x 32mm  
Measures: 6.3" x 6.3" x 1.25"

Max capacità: 2000g  
Max capacity: 2000g

Accuratezza: 0.1g  
Accuracy: 0.1g

### ACAIA LUNAR

V1293



Modalità di pesatura  
Weighing mode



Modalità doppio display  
Double display mode



Auto tara  
Auto tare mode



Avvio automatico timer  
Timer auto start



Modalità auto tara e timer automatici  
Auto-tare auto-start timer Mode



Avvio auto tara e timer automatico  
Automatic auto-tare timer start

#### DATI TECNICI | TECHNIC INFO

Materiale: Policarbonato  
Material: Polycarbonate

Dimensioni: 105mm x 105mm x 15mm  
Measures: 4.1" x 4.1" x 0.6"

Max capacità: 2000g  
Max capacity: 2000g

Accuratezza: 0.1g  
Accuracy: 0.1g

#### APP SUITE



Brewguide



Brewmaster



Brewbar



Acaia coffee



Acaia updater

## TERMOMETRI ADESIVI LABEL THERMOMETER



V1294  
Termometro adesivo  
a cristalli liquidi  
Liquid crystal label  
thermometer

### DATI TECNICI TECHNIC INFO

Scala di T°: 45.0 to 75.0°C  
T° scale: 113.0 to 167.0°F

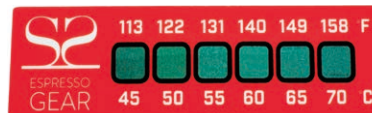

V1295  
Termometro adesivo  
a cristalli liquidi  
Liquid crystal label  
thermometer

### DATI TECNICI TECHNIC INFO

Scala di T°: 45.0 to 70.0°C  
T° scale: 113.0 to 158.0°F

## TERMOMETRI A SONDA PROBE THERMOMETERS



V091  
Termometro analogico  
per lattiera  
Analog thermometer for  
milk pitcher

### DATI TECNICI TECHNIC INFO

Scala di T°: -10.0 to 100.0°C  
T° scale: 14 to 212°F



V129/5  
Termometro digitale  
con sonda  
Digital probe  
thermometer

### DATI TECNICI TECHNIC INFO

Scala di T°: -50.0 to 150.0°C  
T° scale: -58.0 to 302°F  
Accuratezza: ±0.1°C  
Accuracy: ±0.5°F



V129/3  
Termometro digitale con sonda fissa  
Digital thermometer with fixed probe

### DATI TECNICI TECHNIC INFO

Scala di T° 50.0 to 150.0°C  
T° Scale -58.0 to 302°F  
Accuratezza ±0.2°C (±0.5°F)  
Accuracy ±0.2°C (±0.5°F)

CAL Check™ verifica automatica della  
calibrazione all'accensione  
Automatically verifies calibration at startup

Protezione IP 65  
IP 65 protection

Compatibile HACCP  
Ideal for HACCP requirement



V129/4  
Termometro digitale con  
cavo flessibile da 1m  
Digital thermometer with  
1m flexible cable

### DATI TECNICI TECHNIC INFO

Scala di T° 50.0 to 150.0°C  
T° Scale -58.0 to 302°F  
Accuratezza ±0.2°C (±0.5°F)  
Accuracy ±0.2°C (±0.5°F)

CAL Check™ verifica automatica della  
calibrazione all'accensione  
Automatically verifies calibration at startup

Protezione IP 65  
IP 65 protection

Compatibile HACCP  
Ideal for HACCP requirement



V019  
Rotolo teflon 10mm  
10mm teflon tape roll

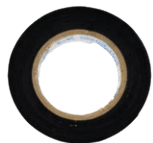

V020  
Nastro isolante plastificato  
Plastic coated insulating tape



V010  
Grasso alimentare 1kg  
Food-grade grease 1kg



MG341  
Pasta silicone per  
termostati (50gr)  
Silicon paste for  
thermostat (50gr)



V135  
Sigilla filetti  
Seal threads



UT101  
Valigetta completa di attrezzi  
Complete tool case

COMPOSTA DA COMPOSED BY



V009  
Spazzolino per doccia  
Shower brush



V009/1  
Spazzolino con  
setole in ottone  
Brush with Brass  
bristles



UT002  
Pinza da idraulico  
Clamp



UT003  
Calibro  
Calibre



UT004  
Chiave a brugola  
a T 3x100  
T-head Allen spanner  
3x100



UT005  
Pinza con becchi curvi  
160mm  
Clamp with curved jaws  
160mm



UT006  
Chiavi comb. 6/22 12pz  
Comb keys 6/22 12pcs



UT007  
Torcia impermeabile  
waterproof torch



UT008  
Set cacciaviti 6pz  
6pcs screwdrivers set



UT009  
Cacciavite nano piatto  
Nano flat screwdriver



UT011  
Chiave a tubo doppia  
12-13  
12-13 Double socket  
wrench



UT012  
Chiave a tubo doppia  
14-15  
14-15 Double socket  
wrench



UT013  
Pennello strozzato in  
plastica  
Plastic chocked  
brush



UT014  
Chiave a pipa N8  
N8 pipw wrench



UT015  
Set di chiavi a brugola  
USAG 280 LTS /S9  
Allen key set (USAG 280  
LTS/S9)



UT016  
Chiave a T USAG 280T/4  
T-handle spanner USAG  
280T/4



UT017  
Punteruolo 6x80  
6x80 Awl



UT001  
Valigetta per attrezzi  
440x390x185  
Tool case 440x390x185



SERRAFILETTI THREADLOCKING



V1297  
 83-54 Serrafiletti  
 83-54 Threadlocking  
 83-54 Adesivo anaerobico serrafiletti forte  
 83-54 High strength threadlocking anaerobic adhesive

ALTA RESISTENZA HIGH STRENGHT

Adesivo a montaggio permanente adatto a tutti i metalli.  
 Resistenza fino a 200°C  
 High strenght permanent lockingh adhesive suitable for all metals  
 Resistance up to 200°C



V1297/1  
 55-02 Serrafiletti  
 55-02 Threadlocking  
 55-02 Adesivo anaerobico serrafiletti a media resistenza  
 55-02 Medium strength threadlocking anaerobic adhesive

MEDIA RESISTENZA MEDIUM STRENGHT

Adesivo a media resistenza che permette lo smontaggio una volta applicato.  
 Adatto a tutti i metalli  
 Medium strenght adhesive that allow disassembling once applied. Suitable for all metals



V1297/2  
 Serrafiletti 55-03  
 55-03 Threadlocking  
 55-03 Adesivo anaerobico serrafiletti a media resistenza  
 55-03 Medium strength threadlocking anaerobic adhesive

MEDIA RESISTENZA MEDIUM STRENGHT

Adesivo a media resistenza che permette lo smontaggio una volta applicato. Adatto a tutti i metalli  
 Resistenza fino a 200°C  
 Medium strenght adhesive that allow disassembling once applied. Suitable for all metals  
 Resistance up to 200°C



V1298  
 24-18 Serrafiletti  
 24-18 Threadlocking  
 24-18 Adesivo anaerobico serrafiletti a bassa resistenza  
 24-18 Low strength threadlocking anaerobic adhesive

BASSA RESISTENZA LOW STRENGHT

Adesivo di bassa resistenza che permette uno smontaggio facilitato una volta applicato. Adatto a tutti i metalli  
 Low strenght adhesive that allow easy disassembling once applied.  
 Suitable for all metals



# MANUTENZIONE MAINTENANCE

---

## SIGILLA FILETTI THREADSEALING

---



V1299

53-14 Sigillafiletti  
53-14 Threadsealing  
53-14 Adesivo anaerobico sigillafiletti a media resistenza  
53-14 Medium strength threadsealing anaerobic adhesive

MEDIA RESISTENZA MEDIUM STRENGTH

Adesivo anaerobico a media resistenza per metalli. Ideale per sigillare raccordi idraulici e pneumatici

Medium strength anaerobic adhesive for metals. Ideal for sealing hydraulic and pneumatic fittings



V1362

Sigillafiletti 18-10  
18-10 Threadsealing  
18-10 Pasta al PTFE per sigillare giunzioni metalliche  
18-10 PTFE paste for sealing metal joints

MEDIA RESISTENZA MEDIUM STRENGTH

Adesivo anaerobico a media resistenza per metalli. Ideale per sigillare raccordi idraulici e pneumatici

Medium strength anaerobic adhesive for metals. Ideal for sealing hydraulic and pneumatic fittings



V1301

Sigillafiletti 18-10  
18-10 Threadsealing  
18-10 Adesivo anaerobico sigillafiletti a bassa resistenza  
18-10 Low strength threadsealing anaerobic adhesive

BASSA RESISTENZA LOW STRENGTH

Adesivo anaerobico per sigillare giunzioni metalliche filettate permettendo comunque uno smontaggio facilitato

Anaerobic adhesive for sealing threaded metal joints while still allowing easy disassembly

## ADESIVI ISTANTANEI INSTANT ADHESIVES

---



V1302

Adesivo istantaneo 14  
14 Instant adhesive

Adesivo Istantaneo ad alta resistenza e media viscosità. Tempo di fissaggio piuttosto lungo che consente il riposizionamento delle parti.

Instant adhesive with high resistance and medium viscosity. Long fixing time allows the repositioning of the parts.



V1300

Adesivo istantaneo 43S  
43S instant adhesive

Adesivo Istantaneo universale a media viscosità, viene suggerito per il rapido incollaggio. Adatto anche come adesivo in area alimentare

Universal Instant Adhesive with medium viscosity, it is suggested for quick gluing. Suitable also as adhesive in food applications

BLOCCANTE ALTA RESISTENZA HIGH STRENGTH LOCKING



V1297/2

Bloccante 83-21

83-21 Locking

Adesivo anaerobico per metalli  
a rapida polimerizzazione per sigillare e bloccare  
giunzioni filettate

Fast curing high strength anaerobic  
adhesive for locking and sealing threads

GUARNIZIONI LIQUIDE LIQUID SEAL



V1296

Guarnizioni liquide 59-10

59-10 liquid seal

Guarnizione anaerobica dotata  
di alta resistenza al calore

Medium strength anaerobic sealant  
with good heat resistance

GRASSO LUBRIFICANTE LUBRICANT GREASE



V1303

Grasso silicone 100g  
100g silicone grease

V1303/1

Grasso silicone 1kg  
1kg silicone grease

V1303/2

Grasso silicone 10kg  
10kg silicone grease

GRASSO SILICONE SILICONE GREASE

Lubrificante e antiadesivo per tutte le combinazioni  
di materiale. Non è infiammabile ed è un ottimo  
isolante elettrico. Registrato NSF

Lubricant and anti-adhesive for each material  
coupling. It is non flammable and is an excellent  
electrical insulator. NSF registered



V1304

Grasso al PTFE 100g  
100g PTFE grease

V1304/1

Grasso al PTFE 1kg  
1kg PTFE grease

V1304/2

Grasso al PTFE 10kg  
10kg PTFE grease

GRASSO SILICONE SILICONE GREASE

Lubrificante ad alte proprietà grazie al PTFE. Indicato per  
tutte le combinazioni di materiali. Non è infiammabile ed  
è un ottimo isolante elettrico. Registrato NSF

Lubricant with high properties due to PTFE. Suitable  
for all material combinations. Non-flammable and an  
excellent electrical insulator. NSF registered

# PULIZIA CLEANING



**V009**  
Spazzolino per doccia con setole in plastica  
Brew head brush with plastic bristles



**V009/N**  
Spazzolino per doccia color nero  
Black brew head brush



**V009/1**  
Spazzolino per doccia con setole in ottone  
Brew head brush with brass bristles



**V009/2**  
Spazzolino per doccia con setole in ottone  
Brew head brush with brass bristles



**V391**  
Pennello per pulizia portafiltri  
Cleaning brush for portafilter



**V346**  
Spazzolino nero per doccia con setole in plastica  
Black brew head brush with black plastic bristles



X3

**V347**  
Kit spazzole di ricambio per puliscidocce  
Replacement brush kit



**V374**  
**V374/N**  
Spazzolino URNEX per doccia con setole in plastica e misurino  
URNEX Black brew head brush with plastic bristles and measuring cup



**V1305**  
Spazzola a vapore per la rimozione di macchie e residui di caffè.  
Steam brush for removing persistent stains and coffee residue.



**V1306**  
Panno a 3 strati nero, in microfibra e silicone  
Black microfiber layer 3 separate layers made out of microfiber and silicone

## DETERGENTI IN POLVERE POWDER CLEANERS



RICAMBI  
**GARDOSI**  
dal 1958



**V132**  
RG NET Detergente per gruppi in polvere 900g  
RG NET 900g powder cleaner for group



**V018/1**  
Detergente per gruppi Pulycaff plus NSF 900g  
Pulycaff NSF 900g powder cleaner for group



**V018/4 (NSF)**  
**V132/2**  
Detergente in polvere 900g Express special  
Powder cleaner 900g Express special



**V018/2**  
Detergente Pulycaff in polvere 570g  
Pulycaff powder cleaner 570g



**V018/3**  
Detergente Pulycaff in polvere 370g  
Pulycaff powder cleaner 370g

DETERGENTI IN BUSTA MONODOSE SINGLE-DOSE BAGS CLEANER



V017/2  
Detergente per gruppi  
in polvere PULYCAFF  
PULYCAFF powder  
cleaner for groups

10pz (20g/pz)



V017B  
PULYCAFF detergente  
per gruppi  
PULYCAFF  
Groups cleaner

1pz (3.5g/pz)

DETERGENTI IN PASTIGLIA TABS CLEANER



V133/3  
ASCOR detergente  
in pastiglie (100pz)  
ASCOR tabs  
cleaner (100pcs)



V133/4  
ASCOR detergente  
in pastiglie (60pz) 2.5g  
ASCOR tabs cleaner  
(60pcs) 2.5g



V133/1  
PULYCAFF detergente  
in pastiglie (60pz) 2.5g  
PULYCAFF tabs  
cleaner (60pcs) 2.5g



V133/2  
PULYCAFF detergente  
in pastiglie (100pz - 1g/pz)  
PULYCAFF tabs  
cleaner (100pz - 1g/pz)



V133/6  
Detergente PULYCAFF  
per superautomatiche  
(70pz - 0.5g/pz)  
PULYCAFF super  
automatic coffee  
machine cleaner 70pz



V133/7  
Detergente PULYCAFF  
per superautomatiche  
(100pz - 1.35g/pz)  
PULYCAFF super  
automatic coffee  
machine cleaner 100pcs



V375  
ASCOR detergente in  
pastiglie (100pz) 1.2g  
ASCOR tabs cleaner  
(100pcs) 1.2g



V133/5  
Detergente PULYCAFF  
per filtri e caraffe 120pz  
PULYCAFF coffee filter  
tabs cleaner 120pcs

# PULIZIA CLEANING

## DETERGENTI LIQUIDI LIQUID CLEANERS



V279/1  
PULYMILK  
4 monodosi  
4 single dose  
PULYMILK



V279/2  
PULYMILK  
30 monodosi  
30 single dose  
PULYMILK



V278/3 (NSF)  
ASCOR EXPRESS 1L  
detergente cappuccinatori  
ASCOR EXPRESS 1L  
cappuccino maker  
detergent



V278/2  
ASCOR EXPRESS 1L  
detergente per gruppi  
ASCOR EXPRESS 1L  
group detergent



V278/1 (NSF)  
PULYMILK PLUS 1L (20 dosi)  
per cappuccinatore  
PULYMILK PLUS 1L (20 doses)  
for cappuccino maker



V114  
Decappante - brillante  
per rame e ottone  
Pickling paste - rinse  
for copper and brass



V115  
1L Sgrassante - lucidante  
professionale per carrozzerie  
1L Degrease - polish for bodywork  
Professional use only

## ANTICALCARE DESCALERS



V136  
Detergente ANTIKAL  
ecologico  
ANTIKAL ecologic  
cleaner



V113  
CHIMIWASH  
Disincrostante acido  
CHIMIWASH acid  
descaler



V141  
CALCINET 1Kg  
decalcificante  
in polvere  
CALCINET 1kg  
descaling powder



V141/1  
ASCOR SOLF 1kg  
disincrostante in polvere  
ASCOR SOLF 1Kg  
descaling powder



V142/1 10pcs  
V142/1B 1pcs  
PULYCLEANER  
decalcificante  
PULYCLEANER  
descaler



V142/2  
ASCOR DC  
10 bustine  
disincrostanti  
ASCOR DC 10  
bags descaler





PULIZIA MACINE E CAMPANA BURRS AND HOPPER CLEANERS



V090 10pcs  
V090B 1pcs  
Pulitore macine  
PULYGRIND in bustina  
PULYGRIND grinder  
cleaner bag



V386  
PULYGRIND HOPPER  
spray per campana  
Spray for hopper  
PULYGRIND HOPPER



V376  
Pulitore in pastiglie  
per macine GRINDZ  
GRINDZ tabs cleaner  
for grinder



V090/1  
PULYGRIND CLEANER polvere  
detergente per macinadosatori  
Cleaner powder for coffee grinder  
PULYGRIND CLEANER

ANTIBATTERICO ANTIBACTERICAL



V349  
PULY BASTERYL spray  
igienizzante per attrezzature e superfici  
PULY BASTERYL spray sanitizer  
for equipment and surfaces

DETERGENTI LAVASTOVIGLIE DISHWASHER CLEANER

RICAMBI  
GARDOSI



V138/1 12L  
RG Clean Bar - detergente lavatazzine  
RG Clean Bar - washer detergent



V139/1 10L  
V139 5L  
RG Brill - brillantante concentrato  
RG Brill- Concentrated brightener

KIT PULIZIA CLEANERS KIT



V279/3  
PULYMILK detergente per lance con  
vaschetta per il lavaggio, 14pz (25ml)  
PULYMILK 14pcs (25ml) wand  
cleaner with wash tank



V380  
Sistema di pulizia  
ad immersione  
Immersion cleaning  
system

# PORTAFILTRI SPECIALI SPECIAL PORTAFILTERS

---

## COPPA SENZA FONDO BOTTOMLESS PORTAFILTER BODY

---



AS062/1	ASTORIA CTS 03	P193/1	LA PAVONI
A101/1	AURORA-BRUGNETTI	LS004/1	LA SCALA
BE028/1	BEZZERA	SP041/1	LA SPAZIALE
BFC249/1	BFC	M098/1	MARZOCCO
BF270/1	BRASILIA	S030/1	NUOVA SIMONELLI
CA202/1	CARIMALI	R113/1	RANCILIO
C249/1	CIMBALI	RY249/1	ROYAL
F997/1	FAEMA	SM299/1	SAN MARCO
F701	FAEMA BASSO E61	SR002/1	SANREMO
FZ112/1	FIORENZATO	VBM094/1	VIBIEMME
FS207/1	FUTURMAT	W561/1	WEGA
GR860/1	GRIMAC		

## PORTAFILTRI SENZA FONDO BOTTOMLESS PORTAFILTER

---

COMPLETO DI MANOPOLA COMPLETE WITH KNOB



AS062/1SF	ASTORIA CTS 03	P193/1SF	LA PAVONI
A101SF	AURORA-BRUGNETTI	LS004SF	LA SCALA
BE028/1SF	BEZZERA	SP041/1SF	LA SPAZIALE
BFC249/1SF	BFC	M098SF	MARZOCCO
BF511SF	BRASILIA	S030/1SF	NUOVA SIMONELLI
CA268/1SF	CARIMALI	R113SF	RANCILIO
C249/1SF	CIMBALI	RY249/1SF	ROYAL
F1052/1SF	FAEMA	SM299/1SF	SAN MARCO
F1052SF	FAEMA BASSO E61	SR002SF	SANREMO
FZ112/1SF	FIORENZATO	VBM094/1SF	VIBIEMME
FS207SF	FUTURMAT	W561/1SF	WEGA
GR860SF	GRIMAC		

# PORTAFILTRI SPECIALI SPECIAL PORTAFILTERS

## ADATTATORI EP-FAP EP-FAP ADAPTOR



V401/4  
Adattatore EP-FAP monodose  
con beccuccio 1 via  
Single-dose EP-FAP adapter  
with 1-way spout



V401/3  
Adattatore EP-FAP monodose  
con emulsionatore  
Single-dose EP-FAP adapter  
with emulsifier



V401/BIDOSE/1  
Adattatore EP-FAP bidose  
con beccuccio 1 via  
EP-FAP bidose adapter  
with 1-way spout



V401/BIDOSE/2  
Adattatore EP-FAP bidose  
con beccuccio 2 vie  
EP-FAP bidose adapter  
with 2-way spout



V401/BIDOSE  
Adattatore EP-FAP bidose  
con emulsionatore  
EP-FAP bidose adapter  
with emulsifier

## PORTAFILTRI PER CAPSULE CAPS PORTAFILTER

### PER CAPSULA EP-FAP MONODOSE PER EP-FAP SINGLE DOSE CAPSULE



BECCUCCIO 1VIA  
1 WAY SPOUT

EMULSIONATORE  
EMULSIFIER

V1307/1

V1307/2

ASTORIA, BEZZERA

V1324/1

V1324/2

AURORA, BRASILIA, FAEMA, FUTURMAT, GRIMAC,  
LA MARZOCCO, WEGA, SANREMO

V1312/1

V1312/2

BFC, FIORENZATO, FAEMA BASSO, RANCILIO  
ROYAL, VBM

V1310/1

V1310/2

CIMBALI

V1382/1

V1382/2

CARIMALI

V1315/1

V1315/2

LA PAVONI

V1319/1

V1319/2

NUOVA SIMONELLI

## PORTAFILTRI PER CAPSULE CAPS PORTAFILTER

### PER CAPSULA EP-FAP BIDOSE PER EP-FAP BI-DOSE CAPSULE



BECCUCCIO 1VIA  
1 WAY SPOUT

BECCUCCIO 2VIE  
2 WAY SPOUT

EMULSIONATORE  
EMULSIFIER

V1307/BIDOSE/1

V1307/BIDOSE/2

V1307/BIDOSE

ASTORIA, BEZZERA

V1324/BIDOSE/1

V1324/BIDOSE/2

V1324/BIDOSE

AURORA, BRASILIA, FAEMA,  
FUTURMAT, GRIMAC,  
LA MARZOCCO, WEGA, SANREMO

V1312/BIDOSE/1

V1312/BIDOSE/2

V1312/BIDOSE

BFC, FIORENZATO, FAEMA BASSO,  
RANCILIO, ROYAL, VBM

V1310/BIDOSE/1

V1310/BIDOSE/2

V1310/BIDOSE

CIMBALI

V1382/BIDOSE/1

V1382/BIDOSE/2

V1382/BIDOSE

CARIMALI

V1315/BIDOSE/1

V1315/BIDOSE/2

V1315/BIDOSE

LA PAVONI

V1319/BIDOSE/1

V1319/BIDOSE/2

V1319/BIDOSE

NUOVA SIMONELLI

# PORTAFILTRI SPECIALI SPECIAL PORTAFILTERS

## ADATTATORI LAVAZZA BLUE LAVAZZA BLUE ADAPTOR



V3792  
FAEMA - WEGA - CASADIO  
Adattatore Lavazza Blue con  
beccuccio 1 via  
Lavazza Blue adapter with  
1-way spout



V3782/1  
RANCILIO  
Adattatore Lavazza Blue  
con beccuccio 1 via  
Lavazza Blue adapter with  
1-way spout



V3793  
FAEMA - WEGA - CASADIO  
Adattatore Lavazza Blue con  
beccuccio 2 vie  
Lavazza Blue adapter with  
2-way spout



V3782/2  
RANCILIO  
Adattatore Lavazza Blue con  
beccuccio 2 vie  
Lavazza Blue adapter with  
2-way spout

## KIT PORTAFILTRO LAVAZZA BLUE LAVAZZA BLUE PORTAFILTER KIT



BECCUCCIO 1VIA  
1 WAY SPOUT

BECCUCCIO 2VIE  
2 WAY SPOUT

V464

V447

FAEMA, WEGA

V427

V427/2

RANCILIO

V443

V443/2

CASADIO

## ADATTATORI DOLCEGUSTO DOLCEGUSTO ADAPTOR



V405  
Adattatore DOLCEGUSTO  
DOLCEGUSTO adapter

V1325	ASTORIA CTS 03	V1333	LA PAVONI
V1326	AURORA-BRUGNETTI	V1334	LA SCALA
V1374	BEZZERA	V1335	LA SPAZIALE
V1375	BFC	V1336	MARZOCCO
V1327	BRASILIA	V1337	NUOVA SIMONELLI
V1383	CARIMALI	V1338	RANCILIO
V1328	CIMBALI	V1377	ROYAL
V1329	FAEMA	V1339	SAN MARCO
V1330	FAEMA BASSO E61	V1340	SANREMO
V1376	FIorenZATO	V1341	VIBIEMME
V1331	FUTURMAT	V1342	WEGA
V1332	GRIMAC		

# PORTAFILTRI SPECIALI SPECIAL PORTAFILTERS

## ADATTATORI CIALDE ESE ESE PODS ADAPTOR



V401/ESE  
Assieme adattatore cialde  
ESE con emulsionatore  
ESE pod adapter with  
emulsifier

## PORTAFILTRO PER CIALDE ESE ESE POD PORTAFILTER

### EMULSIONATORE EMULSIFIER



V1307/ESE	ASTORIA, BEZZERA
V1324/ESE	AURORA, BRASILIA, FAEMA, FUTURMAT, GRIMAC, LA MARZOCCO, WEGA, SANREMO
V1312/ESE	BFC, FIORENZATO, FAEMA BASSO, RANCILIO, ROYAL, VBM
V1310/ESE	CIMBALI
V1382/ESE	CARIMALI
V1315/ESE	LA PAVONI
V1319/ESE	NUOVA SIMONELLI
V1320/ESE	LA SCALA

## PORTAFILTRI SENZA FONDO BOTTOM LESS PORTAFILTERS

### CON FILTRO DA 21g 21g FILTER INCLUDED



V1385	ASTORIA CTS 03	V1397	LA PAVONI
V1386	AURORA-BRUGNETTI	V1398	LA SCALA
V1387	BEZZERA	V1399	LA SPAZIALE
V1388	BFC	V1400	MARZOCCO
V1389	BRASILIA	V1401	NUOVA SIMONELLI
V1390	CARIMALI	V1402	RANCILIO
V1391	CIMBALI	V1403	ROYAL
V1392	FAEMA	V1404	SAN MARCO
V1393	FAEMA BASSO E61	V1405	SANREMO
V1394	FIORENZATO	V1406	VIBIEMME
V1395	FUTURMAT	V1407	WEGA
V1396	GRIMAC		



# MANICI IN LEGNO WOODEN HANDLE

---

## OLIVO OLIVE TREE

---



V2043

Manico in legno di olivo - Forma classica  
Olive wood handle - Classic shape

V2049

Manico in legno di olivo - Forma Elegance  
Olive wood handle - Elegance shape

Manico in legno pregiato ed elegante, realizzato con maestria da abili artigiani, questo manico rappresenta un connubio perfetto tra bellezza naturale e praticità. La lavorazione del legno è eseguita con grande attenzione ai dettagli. Venature, nodi e caratteristiche uniche del legno sono preservati e talvolta accentuati, aggiungendo un tocco distintivo e unico al manico

A fine and elegant wooden handle, skilfully crafted by skilled artisans, this handle represents a perfect combination of natural beauty and practicality. The woodwork is carried out with great attention to detail. Grains, knots and unique wood characteristics are preserved and sometimes accentuated, adding a distinctive and unique touch to the handle.

## CERRO TURKEY OAK

---



V2041

Manico in legno di cerro - Forma classica  
Turkey oak wood handle - Classic shape

V2047

Manico in legno di cerro - Forma Elegance  
Turkey oak wood handle - Elegance shape

Il manico in legno di cerro varia da tonalità più chiare a sfumature più scure, offrendo un'ampia gamma di opzioni estetiche. Grazie alla sua durezza, il legno di cerro offre una resistenza superiore, garantendo che il manico sia robusto e durevole nel tempo.

The turkey oak wood handle varies from lighter to darker shades, offering a wide range of aesthetic options. Due to its hardness, turkey oak offers superior strength, ensuring that the handle is robust and durable.

## ROVERE SCURO DARK OAK

---



V2040

Manico in legno di rovere scuro - Forma classica  
Dark oak wood handle - Classic shape

V2046

Manico in legno di rovere scuro - Forma Elegance  
Dark oak wood handle - Elegance shape

La grana del legno di rovere scuro è spesso caratterizzata da venature pronunciate e profonde, che aggiungono una dimensione artistica al manico.

La superficie levigata è morbida al tatto, permettendo una sensazione di qualità e precisione nell'impugnatura. Il rovere è noto per la sua durata nel tempo, e un manico realizzato con questo legno può resistere a un uso intensivo senza comprometterne la struttura.

The dark oak wood grain is often characterised by pronounced and deep veins, which add an artistic dimension to the handle. The polished surface is soft to the touch, allowing a feeling of quality. Oak is known for its durability, and a handle made from this wood can withstand intensive use without compromising its structure. This wood can withstand intensive use without compromising its structure.

## NOCE WALNUT

---



V2042

Manico in legno di noce - Classic  
Walnut wood handle - Classic

V2048

Manico in legno di noce - Elegance  
Walnut wood handle - Elegance

Manico in legno di noce che sposa la bellezza naturale con la funzionalità pratica. Il noce, è noto per la sua ricca colorazione e la grana distintiva, che lo rendono un'opzione eccellente per manici pregiati. La lavorazione artigianale di un manico in legno di noce prevede la preservazione e talvolta l'accentuazione di queste caratteristiche, contribuendo a creare un'opera d'arte autentica.

A walnut handle that marries natural beauty with practical functionality. Walnut is known for its rich colouring and distinctive grain, making it an excellent option for fine handles. The craftsmanship of a walnut handle involves preserving and sometimes accentuating these characteristics, helping to create an authentic work of art.

## MULTILEGNO MULTI-WOOD

---



V2044

Manico multistrato - Classic  
Multi-layer handle - Classic

V2050

Manico multistrato - Elegance  
Multi-layer handle - Elegance

La combinazione di legni diversi contribuisce a migliorare la resistenza e la durabilità complessiva del manico. Inoltre, la varietà estetica aggiunta dalla presenza di più legni rende questo manico visivamente attraente e unico.

The combination of different woods contributes to the overall strength and durability of the handle. In addition, the aesthetic variety added by the presence of multiple woods makes this neck visually attractive and unique.

## RESINA E OLIVO RESIN AND OLIVE TREE

---



V2045

Manico in legno di olivo e resina - Classic  
Olive wood and resin handle - Classic

V2051

Manico in legno di olivo e resina - Elegance  
Olive wood and resin handle - Elegance

Questi manici in legno di olivo e resina, creato da abili artigiani, sono un'opera d'arte che fonde la bellezza naturale del legno di olivo con la creatività e la modernità della resina.

La combinazione di questi materiali non solo crea un manico esteticamente accattivante ma fornisce anche una robustezza e una durata superiori. La resina funge da strato protettivo, preservando il legno nel tempo e conferendo al manico una finitura lucida.

These olive wood and resin handles, created by skilled craftsmen, are a work of art that blends the natural beauty of olive wood with the creativity and modernity of resin.

The combination of these materials not only creates an aesthetically appealing handle but also provides superior strength and durability. The resin acts as a protective layer, preserving the wood over time and giving the handle a glossy finish.

## C094

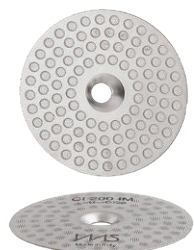

Doccia da competizione CIMBALI 200 micron  
CIMBALI competition shower 200 micron

Membrana integrata creata direttamente all'interno del corpo della doccia

Integrated membrane created directly inside the shower body

COMPATIBILE PER AVAIALE FOR

ASTORIA ELEKTRA FRACINO LA CIMBALI CARIMALI

### DATI TECNICI TECHNIC INFO

ØESTERNO = 51.9mm ØFORI = 3mm  
ØEXTERNAL = 51.9mm ØHOLES = 3mm

Foro centrale = M5 Distribuzione circolare  
Central hole = M5 Circular distribution

## F274



Doccia da competizione E/61 35 micron  
E/61 competition shower 35 micron

CIANFRINATURA: Membrana fissata al corpo della doccia e al disco di supporto mediante piegatura del materiale

Membrane attached to the shower body and to the supporting disk by bending the material

COMPATIBILE PER AVAIALE FOR

SLAYER K.V.D.W. FAEMA VIBIEMME WEGA ASCASO BEZZERA BFC BIANCHI BRASILIA D.I.D ECM EXPOBAR FIORENZATO GRIMAC  
IBERITAL LA NUOVA ERA LA SCALA L'ORCHESTRALE QUALITY ESPRESSO ROCKET ROYAL FIRST SANREMO SV SAB VFA E61 STANDARD

### DATI TECNICI TECHNIC INFO

ØCORPO = 56.5mm ØBORDO = 60mm  
ØBODY = 56.5mm ØEDGE = 60mm

ØFORI = 2.5mm N°FORI = 120  
ØHOLES = 2.5mm N°HOLES = 120

Distribuzione circolare Altezza parete = 17mm  
Circular distribution Wall height = 17mm

## F275



Doccia da competizione E/61 200 micron  
E/61 competition shower 200 micron

Membrana fissata al corpo della doccia e al disco di supporto mediante piegatura del materiale

Membrane attached to the shower body and to the supporting disk by bending the material

COMPATIBILE PER AVAIALE FOR

SLAYER K.V.D.W. FAEMA VIBIEMME WEGA ASCASO BEZZERA BFC BIANCHI BRASILIA D.I.D ECM EXPOBAR FIORENZATO GRIMAC  
IBERITAL LA NUOVA ERA LA SCALA L'ORCHESTRALE QUALITY ESPRESSO ROCKET ROYAL FIRST SANREMO SV SAB VFA E61 STANDARD

### DATI TECNICI TECHNIC INFO

ØCORPO = 56.5mm ØBORDO = 60mm  
ØBODY = 56.5mm ØEDGE = 60mm

ØFORI = 3mm N°FORI = 98  
ØHOLES = 3mm N°HOLES = 98

Distribuzione circolare Altezza parete = 17mm  
Circular distribution Wall height = 17mm

## M097



Doccia da competizione LA MARZOCCO 200 micron  
LA MARZOCCO competition shower 200 micron

Membrana integrata creata direttamente all'interno del corpo della doccia

Integrated membrane created directly inside the shower body

COMPATIBILE PER AVAIALE FOR

LA MARZOCCO SYNESSO SLAYER CARIMALI

### DATI TECNICI TECHNIC INFO

ØESTERNO = 56.4mm ØINTERNO = 55.4mm  
ØEXTERNAL = 56.4mm ØINTERNAL = 55.4mm

ØFORO CENT. = 7mm N°FORI = 98 Ø 3mm  
ØCENTRAL HOLE = 7mm N°HOLES = 98 Ø 3mm

Distribuzione circolare Altezza parete = 5mm  
Circular distribution Wall height = 5mm



### S035

Doccia da competizione SIMONELLI 200 micron  
SIMONELLI competition shower 200 micron

Membrana integrata creata direttamente all'interno del corpo della doccia

Integrated membrane created directly inside the shower body

**COMPATIBILE PER AVAIABLE FOR**

NUOVA SIMONELLI VICTORIA ARDUINO

#### DATI TECNICI TECHNIC INFO

ØESTERNO = 56.4mm	ØINTERNO = 55.4mm
ØEXTERNAL = 56.4mm	ØINTERNAL = 55.4mm
ØFORO CENT. = M6	N°FORI = 98 Ø 3mm
ØCENTRAL HOLE = M6	N°HOLES = 98 Ø 3mm
Distribuzione circolare	Altezza parete = 3.2mm
Circular distribution	Wall height = 3.2mm



### S035/1

Doccia da competizione SIMONELLI 35 micron  
SIMONELLI competition shower 35 micron

Membrana integrata creata direttamente all'interno del corpo della doccia

Integrated membrane created directly inside the shower body

**COMPATIBILE PER AVAIABLE FOR**

NUOVA SIMONELLI VICTORIA ARDUINO

#### DATI TECNICI TECHNIC INFO

ØESTERNO = 57.5mm	ØINTERNO = 55.5mm
ØEXTERNAL = 57.5mm	ØINTERNAL = 55.5mm
ØFORO CENT. = M6	Altezza parete = 4.4mm
ØCENTRAL HOLE = M6	Wall height = 4.4mm
N°FORI = 112 Ø 2mm	Distribuzione quadrata
N°HOLES = 112 Ø 2mm	Square distribution



### SM229

Doccia da competizione SAN MARCO 200 micron  
SAN MARCO competition shower 200 micron

Membrana integrata creata direttamente all'interno del corpo della doccia

Integrated membrane created directly inside the shower body

**COMPATIBILE PER AVAIABLE FOR**

NUOVA SIMONELLI VICTORIA ARDUINO

#### DATI TECNICI TECHNIC INFO

ØESTERNO = 48mm	Foro centrale = 5mm
ØEXTERNAL = 48mm	Central hole = 5mm
ØFORI = 3mm	N°FORI = 98
ØHOLES = 3mm	N°HOLES = 98
Distribuzione circolare	
Circular distribution	





## C087

Filtro una tazza da competizione 6/9g  
1 cup competition filter 6/9g



### DATI TECNICI TECHNICAL INFO

ØBORDO = 68mm    ØCORPO = 60mm    Altezza = 24.5mm    N°FORI = 253    Ø 0.3mm  
ØEDGE = 68mm    ØBODY = 60mm    Height = 24.5mm    N°HOLES = 253    Ø 0.3mm

Area forata = Ø30mm    Distribuzione circolare  
Perforated area = Ø30mm    Circular distribution

### LAVORAZIONI ESEGUITE PROCESS PERFORMED

Decappaggio    Elettrolucidatura    Burrattatura  
Pickling    Electropolishing    Tumbling

### COMPATIBILE PER AVAILABLE FOR

LA CIMBALI    CARIMALI    GAGGIA

## C088

Filtro due tazze da competizione 12/18g  
2 cup competition filter 12/18g



### DATI TECNICI TECHNICAL INFO

ØBORDO = 68mm    Altezza = 24.5mm    ØCORPO = 60mm    N°FORI = 253    Ø 0.3mm  
ØEDGE = 68mm    Height = 24.5mm    ØBODY = 60mm    N°HOLES = 253    Ø 0.3mm

Area forata = Ø44mm    Distribuzione circolare  
Perforated area = Ø44mm    Circular distribution

### LAVORAZIONI ESEGUITE PROCESS PERFORMED

Decappaggio    Elettrolucidatura    Burrattatura  
Pickling    Electropolishing    Tumbling

### COMPATIBILE PER AVAILABLE FOR

LA CIMBALI    CARIMALI    GAGGIA

## C089

Filtro due tazze da competizione 16/22g  
2 cup competition filter 16/22g



### DATI TECNICI TECHNICAL INFO

ØBORDO = 68mm    Altezza = 24.5mm    ØCORPO = 60mm    N°FORI = 253    Ø 0.3mm  
ØEDGE = 68mm    Height = 24.5mm    ØBODY = 60mm    N°HOLES = 253    Ø 0.3mm

Area forata = Ø44mm    Distribuzione circolare  
Perforated area = Ø44mm    Circular distribution

### LAVORAZIONI ESEGUITE PROCESS PERFORMED

Decappaggio    Elettrolucidatura    Burrattatura  
Pickling    Electropolishing    Tumbling

### COMPATIBILE PER AVAILABLE FOR

LA CIMBALI    CARIMALI    GAGGIA

## F23001

14/16gr

## F23002

17/19gr

## F23003

20/22,5gr

## F23004

22/24,5gr

Filtro IMS BIG BANG  
IMS BIG BANG filter



### DATI TECNICI TECHNICAL INFO

ØBORDO = 70mm    ØCORPO = 60mm    N°FORI = 585    Ø 0.3mm  
ØEDGE = 70mm    ØBODY = 60mm    N°HOLES = 585    Ø 0.3mm

Area forata = Ø49mm    Distribuzione circolare con sezione trasversale conica  
Perforated area = Ø49mm    Circular distribution with conical cross-section

### LAVORAZIONI ESEGUITE PROCESS PERFORMED

Decappaggio    Elettrolucidatura    Burrattatura  
Pickling    Electropolishing    Tumbling





**W1213**  
 Filtro una tazze da competizione 6/8g  
 1 cup competition filter 6/8g

DATI TECNICI TECHNICAL INFO

ØBORDO = 70mm Altezza = 24.5mm ØCORPO = 60mm N°FORI = 177 Ø0.3mm Area forata = Ø30mm Distribuzione circolare  
 ØEDGE = 70mm Height = 24.5mm ØBODY = 60mm N°HOLES = 177 Ø0.3mm Perforated area = Ø30mm Circular distribution  
 Elettrolucidatura Burrattatura Decappaggio  
 Electropolishing Tumbling Pickling



**W1214**  
 Filtro una tazza da competizione 6/8g  
 1 cup competition filter 6/8g

DATI TECNICI TECHNICAL INFO

ØBORDO = 70mm Altezza = 26.5mm ØCORPO = 60mm N°FORI = 253 Ø0.3mm Area forata = Ø30mm Distribuzione circolare  
 ØEDGE = 70mm Height = 26.5mm ØBODY = 60mm N°HOLES = 253 Ø0.3mm Perforated area = Ø30mm Circular distribution  
 Elettrolucidatura Burrattatura  
 Electropolishing Tumbling



**W1215**  
 Filtro due tazze da competizione 12/18g  
 2 cup competition filter 12/18g

DATI TECNICI TECHNICAL INFO

ØBORDO = 70mm Altezza = 24.5mm ØCORPO = 60mm N°FORI = 641 Ø0.3mm Area forata = Ø44mm Distribuzione circolare  
 ØEDGE = 70mm Height = 24.5mm ØBODY = 60mm N°HOLES = 641 Ø0.3mm Perforated area = Ø44mm Circular distribution  
 Elettrolucidatura Burrattatura  
 Electropolishing Tumbling



**W1216**  
 Filtro due tazze da competizione 14/20g  
 2 cup competition filter 14/20g

DATI TECNICI TECHNICAL INFO

ØBORDO = 70mm Altezza = 26.5mm ØCORPO = 60mm N°FORI = 641 Ø0.3mm Area forata = Ø49mm Distribuzione circolare  
 ØEDGE = 70mm Height = 26.5mm ØBODY = 60mm N°HOLES = 641 Ø0.3mm Perforated area = Ø49mm Circular distribution  
 Elettrolucidatura Burrattatura  
 Electropolishing Tumbling



**W1217**  
 Filtro due tazze da competizione 18/22g  
 2 cup competition filter 18/22g

DATI TECNICI TECHNICAL INFO

ØBORDO = 70mm Altezza = 28.5mm ØCORPO = 60mm N°FORI = 715 Ø0.3mm Area forata = Ø49mm Distribuzione circolare  
 ØEDGE = 70mm Height = 28.5mm ØBODY = 60mm N°HOLES = 715 Ø0.3mm Perforated area = Ø49mm Circular distribution  
 Elettrolucidatura Burrattatura  
 Electropolishing Tumbling

W1213 W1214 W1215 W1216 W1217 COMPATIBILE PER AVAILABLE FOR

LA MARZOCCO SYNESSO KEES VAN DER WESTEN NUOVA SIMONELLI VICTORIA ARDUINO RANCILIO PROMAC MAGISTER ASTORIA CONTI  
 ELEKTRA LA PAVONI FRACINO FAEMA VIBIEMME WEGA ASCASO BEZZERA BFC BIANCHI BRASILIA D.I.D L'ORCHESTRALE ECM EXPOBAR  
 FIORENTATO GRIMAC IBERITAL LA NUOVA ERA LA SCALA QUALITY ESPRESSO ROCKET ROYAL FIRST SANREMO SV SAB VFA E61 STANDARD

## Barista

F22860



Filtro specialty una tazza BOB 10g  
Specialty 1 cup competition filter BOB 10g

Innovativo e versatile, con doppia funzione: per espresso macinato e cialde ESE. La sua forma arrotondata aiuta a pressare il macinato con facilità e in modo uniforme e agevola l'estrazione. Dose minima di macinato consigliata 8,5 - 9 grammi in base dal tipo di caffè.

Innovative and versatile, with dual function: for ground espresso and ESE pods. Its rounded shape helps to press the ground coffee easily and evenly and facilitates the extraction. Recommended minimum dose of ground coffee is 8.5 - 9 grams depending on the type of coffee.

COMPATIBILE PER AVAIALE FOR

ASTORIA BEZZERA BFC BOSCO BREVILLE PRO SERIES CARIMALI CIMBALI DALLA CORTE (58mm) ELEKTRA EVOCA FAEMA LELIT LA MARZOCCO LA NUOVA ERA NUOVA SIMONELLI LA PAVONI MAVAM PASQUINI PROFITEC PROMAC RANCILIO QUICK MILL ROCKET SANREMO SLAYER SYNESSO VICTORIA ARDUINO WEGA

F22861



Filtro specialty due tazze BOB 16g  
Specialty 2 cup competition filter BOB 16g

Studiato per ottenere un'estrazione uniforme e costante, per un espresso dal gusto dolce, intenso ed equilibrato. Converte il flusso di caffè in estrazione verso il centro più velocemente e aiuta ad allargare la macinatura grazie alla sua forma e foratura creando meno channeling. Il numero indicato sul filtro coincide con la grammatura massima consigliata.

Designed to achieve an even and constant extraction for a sweet, intense and balanced espresso taste. It converges the flow of extracted coffee towards the centre more quickly and helps to enlarge the grind thanks to its shape and perforation, creating less channeling. The number indicated on the filter coincides with the maximum recommended weight.

COMPATIBILE PER AVAIALE FOR

ASTORIA BEZZERA BFC BOSCO BREVILLE PRO SERIES CARIMALI CIMBALI DALLA CORTE (58mm) ELEKTRA EVOCA FAEMA LELIT LA MARZOCCO LA NUOVA ERA NUOVA SIMONELLI LA PAVONI MAVAM PASQUINI PROFITEC PROMAC RANCILIO QUICK MILL ROCKET SANREMO SLAYER SYNESSO VICTORIA ARDUINO WEGA

F22862



Filtro specialty due tazze BOB 18g  
Specialty 2 cup competition filter BOB 18g

Studiato per ottenere un'estrazione uniforme e costante, per un espresso dal gusto dolce, intenso ed equilibrato. Converte il flusso di caffè in estrazione verso il centro più velocemente e aiuta ad allargare la macinatura grazie alla sua forma e foratura creando meno channeling. Il numero indicato sul filtro coincide con la grammatura massima consigliata.

Designed to achieve an even and constant extraction for a sweet, intense and balanced espresso taste. It converges the flow of extracted coffee towards the centre more quickly and helps to enlarge the grind thanks to its shape and perforation, creating less channeling. The number indicated on the filter coincides with the maximum recommended weight.

COMPATIBILE PER AVAIALE FOR

ASTORIA BEZZERA BFC BOSCO BREVILLE PRO SERIES CARIMALI CIMBALI DALLA CORTE (58mm) ELEKTRA EVOCA FAEMA LELIT LA MARZOCCO LA NUOVA ERA NUOVA SIMONELLI LA PAVONI MAVAM PASQUINI PROFITEC PROMAC RANCILIO QUICK MILL ROCKET SANREMO SLAYER SYNESSO VICTORIA ARDUINO WEGA

F22863



Filtro specialty due tazze BOB 21g  
Specialty 2 cup competition filter BOB 21g

Studiato per ottenere un'estrazione uniforme e costante, per un espresso dal gusto dolce, intenso ed equilibrato. Converte il flusso di caffè in estrazione verso il centro più velocemente e aiuta ad allargare la macinatura grazie alla sua forma e foratura creando meno channeling. Il numero indicato sul filtro coincide con la grammatura massima consigliata.

Designed to achieve an even and constant extraction for a sweet, intense and balanced espresso taste. It converges the flow of extracted coffee towards the centre more quickly and helps to enlarge the grind thanks to its shape and perforation, creating less channeling. The number indicated on the filter coincides with the maximum recommended weight.

COMPATIBILE PER AVAIALE FOR

ASTORIA BEZZERA BFC BOSCO BREVILLE PRO SERIES CARIMALI CIMBALI DALLA CORTE (58mm) ELEKTRA EVOCA FAEMA LELIT LA MARZOCCO LA NUOVA ERA NUOVA SIMONELLI LA PAVONI MAVAM PASQUINI PROFITEC PROMAC RANCILIO QUICK MILL ROCKET SANREMO SLAYER SYNESSO VICTORIA ARDUINO WEGA

## Barista

F22864

Filtro specialty una tazza Renato 8g  
Specialty 1 cup competition filter Renato 8g



Filtro innovativo e rivoluzionario sotto l'aspetto estrattivo e di design. Grazie alla sua linea ed al suo pozzetto si ottiene un'estrazione pulita, omogenea e bilanciata. Rispetta gli aromi e le caratteristiche del chicco trasferendoli in tazza. Perfetto per il classico cappuccino  
Innovative and revolutionary filter in terms of extraction and design. Thanks to its line and well, is achieved a clean, homogeneous and balanced extraction. It respects the aromas and characteristics of the beans, transferring them into the cup. Perfect for the classic cappuccino

COMPATIBILE PER AVAIALE FOR

ASCASO BEZZERA BFC BIANCHI CASADIO ECM EXPOBAR FAEMA GRIMAC IBERITAL  
LA NUOVA ERA PROMAC RENEKA SANREMO LA SCALA VIBIEMME WEGA

F22865

Filtro specialty una tazza Renato 10g  
Specialty 1 cup competition filter Renato 10g



Filtro innovativo e rivoluzionario sotto l'aspetto estrattivo e di design. Grazie alla sua linea ed al suo pozzetto si ottiene un'estrazione pulita, omogenea e bilanciata. Rispetta gli aromi e le caratteristiche del chicco trasferendoli in tazza.

Innovative and revolutionary filter in terms of extraction and design. Thanks to its line and well is achieved a clean, homogeneous and balanced extraction. It respects the aromas and characteristics of the bean by transferring them into the cup.

COMPATIBILE PER AVAIALE FOR

ASCASO BEZZERA BFC BIANCHI CASADIO ECM EXPOBAR FAEMA GRIMAC IBERITAL  
LA NUOVA ERA PROMAC RENEKA SANREMO LA SCALA VIBIEMME WEGA

F22867

Filtro specialty due tazze Renato 16g  
Specialty 2 cup competition filter Renato 16g



Studiato per ottenere un'estrazione uniforme e costante, per un espresso dal gusto dolce, intenso ed equilibrato. Converte il flusso di caffè in estrazione verso il centro più velocemente e aiuta ad allargare la macinatura grazie alla sua forma e foratura creando meno channeling. Il numero indicato sul filtro coincide con la grammatura massima consigliata.

Designed to achieve an even and constant extraction for a sweet, intense and balanced espresso taste. It converges the flow of extracted coffee towards the centre more quickly and helps to enlarge the grind thanks to its shape and perforation, creating less channeling. The number indicated on the filter coincides with the maximum recommended weight.

COMPATIBILE PER AVAIALE FOR

ASCASO BEZZERA BFC BIANCHI CASADIO ECM EXPOBAR FAEMA GRIMAC IBERITAL  
LA NUOVA ERA PROMAC RENEKA SANREMO LA SCALA VIBIEMME WEGA

F22868

Filtro specialty due tazze Renato 18g  
Specialty 2 cup competition filter Renato 18g



Studiato per ottenere un'estrazione uniforme e costante, per un espresso dal gusto dolce, intenso ed equilibrato. Converte il flusso di caffè in estrazione verso il centro più velocemente e aiuta ad allargare la macinatura grazie alla sua forma e foratura creando meno channeling. Il numero indicato sul filtro coincide con la grammatura massima consigliata.

Designed to achieve an even and constant extraction for a sweet, intense and balanced espresso taste. It converges the flow of extracted coffee towards the centre more quickly and helps to enlarge the grind thanks to its shape and perforation, creating less channeling. The number indicated on the filter coincides with the maximum recommended weight.

COMPATIBILE PER AVAIALE FOR

ASCASO BEZZERA BFC BIANCHI CASADIO ECM EXPOBAR FAEMA GRIMAC IBERITAL  
LA NUOVA ERA PROMAC RENEKA SANREMO LA SCALA VIBIEMME WEGA

F22869



Filtro specialty una tazza Renato 21g  
Specialty 1 cup competition filter Renato 21g

Filtro innovativo e rivoluzionario sotto l'aspetto estrattivo e di design. Grazie alla sua linea ed al suo pozzetto si ottiene un'estrazione pulita, omogenea e bilanciata. Rispetta gli aromi e le caratteristiche del chicco trasferendoli in tazza. Un filtro con un spettro gustativo ampio e ricco. Il numero indicato sul filtro o sul contenitore coincide con la grammatura massima consigliata.

Innovative and revolutionary filter in terms of extraction and design. Thanks to its line and well, is achieved a clean, homogeneous and balanced extraction. It respects the aromas and characteristics of the bean by transferring them into the cup. A filter with a broad and rich taste spectrum. The number indicated on the filter or container coincides with the maximum recommended weight.

COMPATIBILE PER AVAIALE FOR

ASCASO BEZZERA BFC BIANCHI CASADIO ECM EXPOBAR FAEMA GRIMAC IBERITAL LA NUOVA ERA PROMAC RENEKA SANREMO LA SCALA VIBIEMME WEGA

F22866



Filtro specialty una tazza Renato 90+ 9-13g  
Specialty 1 cup competition filter Renato 90+ 9-13

Filtro ideato per i caffè specialty e chi vuole sperimentare con grammature diverse, caffè di altura, miscele particolari e monorigini. Innovativo e rivoluzionario sotto l'aspetto estrattivo. Grande flessibilità di estrazione e personalizzazione con dosi tra i 9 ed i 13 grammi, per un gusto pulito e bilanciato. Il nome 90+ fa riferimento ai caffè di qualità che hanno un punteggio superiore ai 90/centesimi

Filter designed for specialty coffees and those who want to experiment with different weights, high altitude coffee, special blends and single origins. Innovative and revolutionary in terms of extraction. Great flexibility of extraction and customisation with doses between 9 and 13 grams, for a clean and balanced taste. The name 90+ refers to the quality coffees that have a score higher than 90/100.

COMPATIBILE PER AVAIALE FOR

ASCASO BEZZERA BFC BIANCHI CASADIO ECM EXPOBAR FAEMA GRIMAC IBERITAL LA NUOVA ERA PROMAC RENEKA SANREMO LA SCALA VIBIEMME WEGA

F22870



Doccia specialty una tazza Bit E61  
Specialty competition shower Bit E61

Doccetta con membrana integrata e disegno di foratura innovativo. Estrazione dall'esterno verso l'interno crea più dolcezza, corpo e rotondità di gusto. Resistente e facile da pulire  
Shower with integrated membrane and innovative perforation design. Extraction from the outside in creates more sweetness, body and roundness of taste. Durable and easy to clean

COMPATIBILE PER AVAIALE FOR

LA MARZOCCO SLAYER SYNESSO

F22871



Filtro specialty una tazza Bit seattle  
Specialty competition filter Bit seattle

Doccetta con membrana integrata e disegno di foratura innovativo. Estrazione dall'esterno verso l'interno crea più dolcezza, corpo e rotondità di gusto. Resistente e facile da pulire  
Shower with integrated membrane and innovative perforation design. Extraction from the outside in creates more sweetness, body and roundness of taste. Durable and easy to clean

COMPATIBILE PER AVAIALE FOR

LA MARZOCCO SLAYER SYNESSO



## LEVAFILTRO COFFEE FILTER REMOVER



V681

Levafiltro IMS  
IMS coffee filter remover

Levafiltro prodotto da IMS, grazie alla sua forma a leva e la punta ribassata agevola l'estrazione del filtro facilitando e velocizzando l'operazione.

L'acciaio indurito e lo spessore da 1mm garantiscono un'ottima forza di esercizio e assicura un'ottima durata e resistenza del levafiltro

Coffee filter remover produced by IMS, thanks to its lever shape and the lowered tip facilitates the extraction of the filter and speed up the operation.

The hardened steel and the 1 mm thickness guarantee an excellent operating force and ensure a long life and resistance of the coffee filter remover



## SMONTADOCCE SHOWER SCREEN REMOVER

V675

Smontadocce  
IMS shower screen remover

Smontadocce con dado esagonale che consente di rimuovere facilmente la doccia dalla macchina da caffè senza sporcarsi o bruciarsi. Si adatta perfettamente al supporto della doccia. Modo d'uso: Inserire completamente lo strumento nel supporto della doccia. Ruotare in senso antiorario per rimuovere la doccia e il supporto della doccia. Pulire la doccia o sostituire la guarnizione del gruppo. Inserire la doccia e riavvitare il gruppo ruotando lo strumento in senso orario.

Shower remover with hexagonal nut for easy removal of the shower from the coffee machine without getting dirty or burnt. It fits perfectly into the shower holder. How to use: Insert the tool fully into the shower holder. Turn anticlockwise to remove the shower and the shower support. Clean the shower or replace the seal on the assembly. Insert the shower and screw the assembly back in by turning the tool clockwise.



V676

Smontadocce  
IMS shower screen remover

Smontadocce con vite a taglio che consente di rimuovere facilmente la doccia dalla macchina da caffè senza sporcarsi o bruciarsi. Si adatta perfettamente al supporto della doccia. Modo d'uso: Inserire completamente lo strumento nel supporto della doccia. Ruotare in senso antiorario per rimuovere la doccia e il supporto della doccia. Pulire la doccia o sostituire la guarnizione del gruppo. Inserire la doccia e riavvitare il gruppo ruotando lo strumento in senso orario.

Shower remover with slotted screw for easy removal of the shower from the coffee machine without getting dirty or burnt. It fits perfectly into the shower holder. How to use: Insert the tool fully into the shower holder. Turn anticlockwise to remove the shower and the shower support. Clean the shower or replace the seal on the assembly. Insert the shower and screw the assembly back in by turning the tool clockwise.





# MACINADOSATORI E MACCHINE DA CAFFE'

---

## COFFEE GRINDERS AND COFFEE MACHINES

### Tramogge e bocchettoni Hopper and hopper outlet

---



F3025  
Coperchio campana conica  
Conical hopper cover



F3026  
Tramoggia trasparente  
alimentare, capacità 1kg.  
a prova di caduta  
Food-grade transparent  
hopper, 1kg capacity,  
drop proof



F3028  
Linguetta per bocchettone  
Filler flap



V045 Ø 57 - 60  
Bocchettone Mazzer  
Mazzer hopper outlet



V046 Ø 55 - 55.5  
Bocchettone Faema  
Faema hopper outlet



V047 Ø 66 - 67  
Bocchettone S. Marco, Aristarco, vari  
S.Marco, Aristarco, various hopper outlet



V048/T Ø 54  
Bocchettone Cimbali  
Cimbali hopper outlet



V048 Ø 51.5 - 52.5  
Bocchettone Rossi, Faema 19, vari  
Rossi, Faema 19, various hopper outlet



V049 Ø 67 - 69  
Bocchettone Fiorenzato  
Fiorenzato hopper outlet

# MACINADOSATORI E MACCHINE DA CAFFÈ

## COFFEE GRINDERS AND COFFEE MACHINES

*Fiorenzato*

IF5A



● V950A  
GRIGIO GRAY

Macinadosatore automatico macine piane Ø64 (230V - 350W)  
Automatic coffee grinder doser flat blade Ø64 (230V - 350W)

### DATI TECNICI

Regolazione macinatura micrometrica  
con ghiera: continua  
Verniciatura: standard  
Forcella: standard  
Potenza: 350 watt  
Tipo di macine: piane  
Diametro macine: Ø 64 mm  
Giri macine: 1350/min (50 Hz)  
1550/min (60 Hz)  
Regolazione dose per battuta: 5,5 - 10 g  
Capacità campana: 1,5 kg  
Capacità dosatore: 250 g  
Peso netto: 14 kg  
Dimensioni: 230x615x270 mm

### TECHNIC INFO

Adjustment: continuous  
Varnishing: standard  
Fork: standard  
Power: 350 watt  
Blades type: flat  
Blades diameter: Ø 64 mm  
Blades revs: 1350/min (50 Hz)  
1550/min (60 Hz)  
Dispenser unit adjustment for shots:  
5,5 - 10 g  
Coffee bean hopper capacity: 1,5 kg  
Doser capacity: 250 g  
Net weight: 14 kg  
Dimensions: 230x615x270 mm

IF5M



● V950M  
GRIGIO GRAY

Macinadosatore manuale macine piane Ø64 (230V - 350W)  
Manual coffee grinder doser flat blade Ø64 (230V - 350W)

### DATI TECNICI

Regolazione macinatura micrometrica  
con ghiera: continua  
Verniciatura: standard  
Forcella: standard  
Potenza: 350 watt  
Tipo di macine: piane  
Diametro macine: Ø 64 mm  
Giri macine: 1350/min (50 Hz)  
1550/min (60 Hz)  
Regolazione dose per battuta: 5,5 - 10 g  
Capacità campana: 1,5 kg  
Capacità dosatore: 250 g  
Peso netto: 14 kg  
Dimensioni: 230x615x270 mm

### TECHNIC INFO

Adjustment: continuous  
Varnishing: standard  
Fork: standard  
Power: 350 watt  
Blades type: flat  
Blades diameter: Ø 64 mm  
Blades revs: 1350/min (50 Hz)  
1550/min (60 Hz)  
Dispenser unit adjustment for shots:  
5,5 - 10 g  
Coffee bean hopper capacity: 1,5 kg  
Doser capacity: 250 g  
Net weight: 14 kg  
Dimensions: 230x615x270 mm

# MACINADOSATORI E MACCHINE DA CAFFÈ

## COFFEE GRINDERS AND COFFEE MACHINES

*Fiorenzato*

IF4GA



● V953A  
GRIGIO GRAY

Macinadosatore automatico macine piane Ø58 (230V - 250W)  
Automatic coffee grinder doser flat blade Ø58 (230V - 250W)

### DATI TECNICI

Regolazione macinatura micrometrica  
con ghiera: continua  
Verniciatura: standard  
Forcella: standard  
Potenza: 250 watt  
Tipo di macine: piane  
Diametro macine: Ø 58 mm  
Giri macine: 1400/min (50 Hz)  
1600/min (60 Hz)  
Regolazione dose per battuta: 5,5 - 10 g  
Capacità campana: 500 g  
Capacità dosatore: 200 g  
Peso netto: 10 kg  
Dimensioni: 169x473x240 mm

### TECHNIC INFO

Ring nut micrometric grinding  
adjustment: continuous  
Varnishing: standard  
Fork: standard  
Power: 250 watt  
Blades type: flat  
Blades diameter: Ø 58 mm  
Blades revs: 1400/min (50 Hz)  
1600/min (60 Hz)  
Dispenser unit adjustment for shots: 5,5 - 10 g  
Coffee bean hopper capacity: 500 g  
Doser capacity: 200 g  
Net weight: 10 kg  
Dimensions: 169x473x240 mm

IF71KA



● V957A  
GRIGIO GRAY

Macinadosatore automatico macine coniche Ø71 (230V - 850W)  
Automatic coffee grinder doser conical blade Ø71 (230V - 850W)

### DATI TECNICI

Regolazione macinatura micrometrica  
con ghiera: continua  
Verniciatura: standard  
Forcella: standard  
Potenza: 850 watt  
Tipo di macine: coniche  
Diametro macine: Ø 71 mm  
Giri macine: 450/min (50 Hz)  
500/min (60 Hz)  
Regolazione dose per battuta: 5,5 - 10 g  
Capacità campana: 1,5 kg  
Capacità dosatore: 250 g  
Peso netto: 21 kg  
Dimensioni: 230x670x270 mm

### TECHNIC INFO

Ring nut micrometric grinding  
adjustment: continuous  
Varnishing: standard  
Fork: standard  
Power: 850 watt  
Blades type: conical  
Blades diameter: Ø 71 mm  
Blades revs: 450/min (50 Hz)  
500/min (60 Hz)  
Dispenser unit adjustment for shots: 5,5 - 10 g  
Coffee bean hopper capacity: 1,5 kg  
Doser capacity: 250 g  
Net weight: 21 kg  
Dimensions: 230x670x270 mm

# MACINADOSATORI E MACCHINE DA CAFFÈ

## COFFEE GRINDERS AND COFFEE MACHINES

*Fiorenzato*

IF63KA



● V960A  
GRIGIO GRAY

Macinadosatore automatico macine coniche Ø63 (220V - 850W)  
Automatic coffee grinder doser conical blade Ø63 (220V - 850W)

### DATI TECNICI

Regolazione macinatura micrometrica  
con ghiera: continua  
Verniciatura: standard  
Forcella: standard  
Potenza: 850 watt  
Tipo di macine: coniche  
Diametro macine: Ø 63 mm  
Giri macine: 300/min (50 Hz)  
300/min (60 Hz)  
Regolazione dose per battuta: 5,5 - 10 g  
Capacità campana: 1,5 kg  
Capacità dosatore: 250 g  
Peso netto: 21 kg  
Dimensioni: 230x670x270 mm

### TECHNIC INFO

Ring nut micrometric grinding  
adjustment: continuous  
Varnishing: standard  
Fork: standard  
Power: 850 watt  
Blades type: conical  
Blades diameter: Ø 63 mm  
Blades revs: 300/min (50 Hz)  
300/min (60 Hz)  
Dispenser unit adjustment for shots: 5,5 - 10 g  
Coffee bean hopper capacity: 1,5 kg  
Doser capacity: 250 g  
Net weight: 21 kg  
Dimensions: 230x670x270 mm

IF6A



● V962A    ● V962A/380 Ø83(380V - 650W)  
GRIGIO GRAY    GRIGIO GRAY

Macinadosatore automatico macine piane Ø83(230V - 650W)  
Automatic coffee grinder doser flat blade Ø83 (230V - 650W)

### DATI TECNICI

Regolazione macinatura micrometrica  
con ghiera: continua  
Verniciatura: standard  
Forcella: standard  
Potenza: 650 watt  
Tipo di macine: piane  
Diametro macine: Ø 83 mm  
Giri macine: 1400/min (50 Hz)  
1600/min (60 Hz)  
Regolazione dose per battuta: 5,5 - 10 g  
Capacità campana: 1,5 kg  
Capacità dosatore: 250 g  
Peso netto: 16 kg  
Dimensioni: 230x670x270 mm

### TECHNIC INFO

Ring nut micrometric grinding  
adjustment: continuous  
Varnishing: standard  
Fork: standard  
Power: 650 watt  
Blades type: flat  
Blades diameter: Ø 83 mm  
Blades revs: 1400/min (50 Hz)  
1600/min (60 Hz)  
Dispenser unit adjustment for shots: 5,5 - 10 g  
Coffee bean hopper capacity: 1,5 kg  
Doser capacity: 250 g  
Net weight: 16 kg  
Dimensions: 230x670x270 mm

IF5DM



● V955M  
GRIGIO GRAY

Macinadosatore manuale macine piane Ø64 (230V - 350W)  
Manual coffee grinder doser flat blade Ø64 (230V - 350W)

#### DATI TECNICI

Regolazione macinatura micrometrica  
con ghiera: continua  
Verniciatura: standard  
Porta sacchetto: standard  
Potenza: 350 watt  
Tipo di macine: piane  
Diametro macine: Ø 64 mm  
Giri macine: 1350/min (50 Hz)  
1550/min (60 Hz)  
Capacità campana: 1,5 kg  
Peso netto: 13 kg  
Dimensioni: 230x615x270 mm

#### TECHNIC INFO

Ring nut micrometric grinding  
adjustment: continuous  
Varnishing: standard  
Bag holder: standard  
Power: 350 watt  
Blades type: flat  
Blades diameter: Ø 64 mm  
Blades revs: 1350/min (50 Hz)  
1550/min (60 Hz)  
Coffee bean hopper capacity: 1,5 kg  
Net weight: 13 kg  
Dimensions: 230x615x270 mm

IF6DM



● V959M  
GRIGIO GRAY

Macinadosatore manuale macine piane Ø83 (230V - 650W)  
Manual coffee grinder doser flat blade Ø83 (230V - 650W)

#### DATI TECNICI

Regolazione macinatura micrometrica  
con ghiera: continua  
Verniciatura: standard  
Porta sacchetto: standard  
Potenza: 650 watt  
Tipo di macine: piane  
Diametro macine: Ø 83 mm  
Giri macine: 1400/min (50 Hz)  
1600/min (60 Hz)  
Capacità campana: 1,5 kg  
Peso netto: 15,5 kg  
Dimensioni: 230x670x270 mm

#### TECHNIC INFO

Ring nut micrometric grinding  
adjustment: continuous  
Varnishing: standard  
Bag holder: standard  
Power: 650 watt  
Blades type: flat  
Blades diameter: Ø 83 mm  
Blades revs: 1400/min (50 Hz)  
1600/min (60 Hz)  
Coffee bean hopper capacity: 1,5 kg  
Net weight: 15,5 kg  
Dimensions: 230x670x270 mm



# MACINADOSATORI E MACCHINE DA CAFFÈ

## COFFEE GRINDERS AND COFFEE MACHINES

*Fiorenzato*

IF4E



● V953  
GRIGIO GRAY

Macinadosatore elettronico macine piane Ø58 (230V - 250W)  
Electronic coffee grinder doser flat blade Ø58 (230V - 250W)

### DATI TECNICI

Regolazione macinatura micrometrica  
con ghiera: continua  
Verniciatura: standard  
Forcella: regolabile, con appoggio  
Regolazione delle dosi: in secondi  
Potenza: 250 watt  
Tipo di macine: piane  
Diametro macine: Ø 58 mm  
Giri macine: 1400/min (50 Hz)  
1600/min (60 Hz)  
Capacità campana: 500 g  
Peso netto: 9 kg  
Dimensioni: 169x473x240 mm

### TECHNIC INFO

Ring nut micrometric grinding  
adjustment: continuous  
Varnishing: standard  
Fork: adjustable, with support  
Doses adjustment: in seconds  
Power: 250 watt  
Blades type: flat  
Blades diameter: Ø 58 mm  
Blades revs: 1400/min (50 Hz)  
1600/min (60 Hz)  
Coffee bean hopper capacity: 500 g  
Net weight: 9 kg  
Dimensions: 169x473x240 mm

IF64EVO



● V954  
GRIGIO GRAY

Macinadosatore elettronico macine piane Ø64 (230V - 350W)  
Electronic coffee grinder doser flat blade Ø64 (230V - 350W)

### DATI TECNICI

Regolazione macinatura micrometrica  
con ghiera: continua  
Verniciatura: standard  
Forcella: regolabile, con appoggio  
Regolazione delle dosi: in secondi  
Potenza: 350 watt  
Tipo di macine: piane  
Diametro macine: Ø 64 mm  
Giri macine: 1350/min (50 Hz)  
1550/min (60 Hz)  
Capacità campana: 1,5 kg  
Peso netto: 13 kg  
Dimensioni: 230x615x270 mm

### TECHNIC INFO

Ring nut micrometric grinding  
adjustment: continuous  
Varnishing: standard  
Fork: adjustable, with support  
Doses adjustment: in seconds  
Power: 350 watt  
Blades type: flat  
Blades diameter: Ø 64 mm  
Blades revs: 1350/min (50 Hz)  
1550/min (60 Hz)  
Coffee bean hopper capacity: 1,5 kg  
Net weight: 13 kg  
Dimensions: 230x615x270 mm

# MACINADOSATORI E MACCHINE DA CAFFÈ

## COFFEE GRINDERS AND COFFEE MACHINES

*Fiorenzato*

IF64E



● V954E Con ventola di raffreddamento automatico  
GRIGIO GRAY With automatic cooling fan

Macinadosatore elettronico macine piane Ø64 (230V - 450W)  
Electronic coffee grinder doser flat blade Ø64 (230V - 450W)

### DATI TECNICI

Regolazione macinatura micrometrica con ghiera: continua  
Verniciatura: standard  
Forcella: regolabile, con appoggio  
Regolazione delle dosi: in secondi  
Potenza: 450 Watt  
Tipo di macine: piane  
Diametro macine: Ø 64 mm  
Giri macine: 1350/min (50 Hz)  
1550/min (60 Hz)  
Capacità campana: 1,5 kg  
Peso netto: 13 kg  
Dimensioni: 230x615x270 mm

### TECHNIC INFO

Ring nut micrometric grinding adjustment: continuous  
Varnishing: standard  
Fork: adjustable, with support  
Doses adjustment: in seconds  
Power: 450 W  
Blades type: flat  
Blades diameter: Ø 64 mm  
Blades revs: 1350/min (50 Hz)  
1550/min (60 Hz)  
Coffee bean hopper capacity: 1,5 kg  
Net weight: 13 kg  
Dimensions: 230x615x270 mm

IF71E



● V957E Con ventola di raffreddamento automatico  
GRIGIO GRAY With automatic cooling fan

Macinadosatore elettronico macine coniche Ø71 (230V - 850W)  
Electronic coffee grinder doser conical blade Ø71 (230V - 850W)

### DATI TECNICI

Regolazione macinatura micrometrica con ghiera: continua  
Verniciatura: standard  
Forcella: regolabile, con appoggio  
Regolazione delle dosi: in secondi  
Potenza: 850 watt  
Tipo di macine: coniche  
Diametro macine: Ø 71 mm  
Giri macine: 300/min (50 Hz)  
300/min (60 Hz)  
Capacità campana: 1,5 kg  
Peso netto: 20 kg  
Dimensioni: 230x670x270 mm

### TECHNIC INFO

Ring nut micrometric grinding adjustment: continuous  
Varnishing: standard  
Fork: adjustable, with support  
Doses adjustment: in seconds  
Power: 850 watt  
Blades type: conical  
Blades diameter: Ø 71 mm  
Blades revs: 300/min (50 Hz)  
300/min (60 Hz)  
Coffee bean hopper capacity: 1,5 kg  
Net weight: 20 kg  
Dimensions: 230x670x270 mm

# MACINADOSATORI E MACCHINE DA CAFFÈ COFFEE GRINDERS AND COFFEE MACHINES

*Fiorenzato*

IF83E



● V958E  
GRIGIO GRAY

Macinadosatore elettronico  
macine piane Ø83 (230V - 650W)  
Electronic coffee grinder doser  
flat blade Ø83 (230V - 650W)

Con sistema brevettato e display touchscreen con tecnologia CapSense.  
With patented system and touchscreen display with CapSense technology.

DATI TECNICI

Regolazione macinatura micrometrica con  
ghiera: continua  
Verniciatura: standard  
Forcella: regolabile, con appoggio  
Regolazione delle dosi: in secondi  
Potenza: 650 watt  
Tipo di macine: piane  
Diametro macine: Ø 83 mm  
Giri macine: 1350/min (50 Hz)  
1550/min (60 Hz)  
Capacità campana: 1,5 kg  
Peso netto: 15 kg  
Dimensioni: 230x670x270 mm

TECHNIC INFO

Ring nut micrometric grinding  
adjustment: continuous  
Varnishing: standard  
Fork: adjustable, with support  
Doses adjustment: in seconds  
Power: 650 watt  
Blades type: flat  
Blades diameter: Ø 83 mm  
Blades revs: 1350/min (50 Hz)  
1550/min (60 Hz)  
Coffee bean hopper capacity: 1,5 kg  
Net weight: 15 kg  
Dimensions: 230x670x270 mm

IF64EVO XGi



● V954EVO/XGi  
GRIGIO GRAY

Macinadosatore elettronico  
macine piane Ø64 (230V - 600W)  
Electronic coffee grinder doser  
flat blade Ø64 (230V - 600W)

Un macinacaffè tecnologico, efficiente, concepito per agevolare il lavoro dei baristi  
A technological, efficient coffee grinder designed to make baristas' work easier.

DATI TECNICI

Regolazione delle dosi: in grammi  
Regolazione macinatura micrometrica  
con ghiera: continua  
Verniciatura: standard  
Forcella: regolabile, con appoggio  
Potenza: 600 Watt  
Tipo di macine: piane  
Diametro macine: Ø 64 mm  
Giri macine: 1350/min (50 Hz)  
1550/min (60 Hz)  
Capacità campana: 1,5 kg  
Peso netto: 15,3 kg  
Dimensioni: 255x635x320 mm

TECHNIC INFO

Doses adjustment: in grams  
Ring nut micrometric grinding  
adjustment: continuous  
Varnishing: standard  
Fork: adjustable, with support  
Power: 600 Watt  
Blades type: flat  
Blades diameter: Ø 64 mm  
Blades revs: 1350/min (50 Hz)  
1550/min (60 Hz)  
Coffee bean hopper capacity: 1,5 kg  
Net weight: 15,3 kg  
Dimensions: 255x635x320 mm

# MACINADOSATORI E MACCHINE DA CAFFÈ

## COFFEE GRINDERS AND COFFEE MACHINES

*Fiorenzato*

IF71KE XGi



● V957E/XGi Con ventola di raffreddamento automatico  
GRIGIO GRAY With automatic cooling fan

Macinadosatore elettronico macine coniche Ø71 (230V - 850W)  
Electronic coffee grinder doser conical blade Ø71 (230V - 850W)

### DATI TECNICI

Regolazione delle dosi: in grammi  
Regolazione macinatura micrometrica  
con ghiera: continua  
Verniciatura: standard  
Forcella: regolabile, con appoggio  
Potenza: 850 watt  
Tipo di macine: coniche  
Diametro macine: Ø 71 mm  
Giri macine: 300/min (50 Hz)  
300/min (60 Hz)  
Capacità campana: 1,5 kg  
Peso netto: 25 kg  
Dimensioni: 255x700x310 mm

### TECHNIC INFO

Doses adjustment: in grams  
Ring nut micrometric grinding  
adjustment: continuous  
Varnishing: standard  
Fork: adjustable, with support  
Power: 850 watt  
Blades type: conical  
Blades diameter: Ø 71 mm  
Blades revs: 300/min (50 Hz)  
300/min (60 Hz)  
Coffee bean hopper capacity: 1,5 kg  
Net weight: 25 kg  
Dimensions: 255x700x310 mm

IF83E XGi



● V958E/XGi  
GRIGIO GRAY

Macinadosatore elettronico macine coniche Ø83 (230V - 850W)  
Electronic coffee grinder doser conical blade Ø83 (230V - 850W)

### DATI TECNICI

Regolazione delle dosi: in grammi  
Regolazione macinatura micrometrica  
con ghiera: continua  
Verniciatura: standard  
Forcella: regolabile, con appoggio  
Potenza: 850 Watt  
Tipo di macine: piane  
Diametro macine: Ø 83 mm  
Giri macine: 1350/min (50 Hz)  
1550/min (60 Hz)  
Capacità campana: 1,5 kg  
Peso netto: 18,6 kg  
Dimensioni: 255x700x310 mm

### TECHNIC INFO

Doses adjustment: in grams  
Ring nut micrometric grinding  
adjustment: continuous  
Varnishing: standard  
Fork: adjustable, with support  
Power: 850 Watt  
Blades type: flat  
Blades diameter: Ø 83 mm  
Blades revs: 1350/min (50 Hz)  
1550/min (60 Hz)  
Coffee bean hopper capacity: 1,5 kg  
Net weight: 18,6 kg  
Dimensions: 255x700x310 mm



# MACINADOSATORI E MACCHINE DA CAFFÈ COFFEE GRINDERS AND COFFEE MACHINES

*Fiorenzato*

IF64E XGi



● V954E/XGi  
GRIGIO GRAY

Macinadosatore elettronico macine coniche Ø64 (230V - 600W)  
Electronic coffee grinder doser conical blade Ø64 (230V - 600W)

## DATI TECNICI

Regolazione delle dosi: in grammi  
Regolazione macinatura micrometrica con ghiera: continua  
Verniciatura: standard  
Forcella: regolabile, con appoggio  
Potenza: 600 watt  
Tipo di macine: piane  
Diametro macine: Ø 64 mm  
Giri macine: 1350/min (50 Hz) - 1550/min (60 Hz)  
Capacità campana: 1,5 kg  
Peso netto: 15,2 kg  
Dimensioni: 255x635x320 mm

## TECHNIC INFO

Doses adjustment: in grams  
Ring nut micrometric grinding adjustment: continuous  
Varnishing: standard  
Fork: adjustable, with support  
Power: 600 watt  
Blades type: flat  
Blades diameter: Ø 64 mm  
Blades revs: 1350/min (50 Hz) - 1550/min (60 Hz)  
Coffee bean hopper capacity: 1,5 kg  
Net weight: 15,2 kg  
Dimensions: 255x635x320 mm

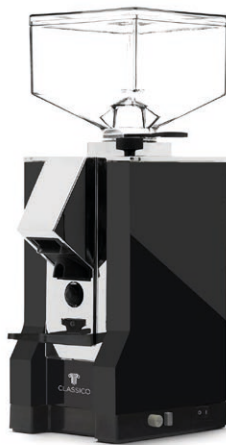

## MIGNON CLASSICO

● Z1300/NO ● Z1300/G  
NERO OPACO BLACK MATT GRIGIO GRAY

Macinadosatore macine piane Ø50 (230V - 310W)  
Coffee grinder doser flat blade Ø50 (230V - 310W)

## DATI TECNICI

Potenza: 310 watt  
Tipo di macine: Piane  
Diametro macine: Ø 50 mm  
Giri macine: 1350/min  
Capacità campana: 300g  
Produzione macinato: 3.2 - 5.4 Kg/h  
Peso netto: 5.6kg  
Dimensioni: 350x120x180 mm

## TECHNIC INFO

Power: 310 watt  
Blades type: Flat  
Blades diameter: Ø 50 mm  
Blades revs: 1350/min  
Coffee bean hopper capacity: 300g  
Espresso point production: 3.2 - 5.4 kg/h  
Net weight: 5.6kg  
Dimensions: 350x120x180 mm



## MIGNON PERFETTO

● Z1301/NO ● Z1301/G  
NERO OPACO BLACK MATT GRIGIO GRAY

Macinadosatore macine piane Ø50 (230V - 310W)  
Coffee grinder doser flat blade Ø50 (230V - 310W)

## DATI TECNICI

Potenza: 310 watt  
Tipo di macine: Piane  
Diametro macine: Ø 50 mm  
Giri macine: 1350/min  
Capacità campana: 300g  
Produzione macinato: 3.6 - 5.7 Kg/h  
Peso netto: 5.6kg  
Dimensioni: 350x120x180 mm

## TECHNIC INFO

Power: 310 watt  
Blades type: Flat  
Blades diameter: Ø 50 mm  
Blades revs: 1350/min  
Coffee bean hopper capacity: 300g  
Espresso point production: 3.6 - 5.7 kg/h  
Net weight: 5.6kg  
Dimensions: 350x120x180 mm



### TUBE

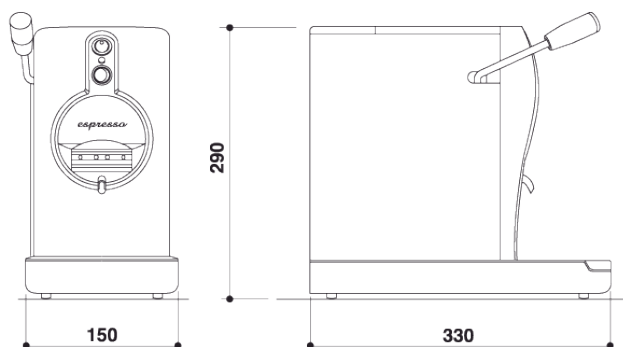

#### DATI TECNICI

Pompa ulka EP4FM: 20 bar  
 Serbatoio acqua: 2 litri  
 Assorbimento: 450 watt  
 Scambiatore: Alluminio  
 Termostato di lavoro: 98°C  
 Termostato di sicurezza: 145°C

#### TECHNIC INFO

Ulka pump EP4FM: 20 bar  
 Water tank: 2 liters  
 Power absorption: 450 watt  
 Exchanger: Aluminum  
 Working thermostat: 98°C  
 Security thermostat: 145°C

#### COLORI DISPONIBILI AVAILABLE COLOURS



NERO  
 BLACK  
 TUB001N/L  
 TUB001N/110V/L



ROSSO  
 RED  
 TUB001R/L



ORO  
 GOLD  
 TUB001ORO/L



BIANCO  
 WHITE  
 TUB001B/L



NICHEL  
 NICKEL  
 TUB001NIK/L



CROMATO  
 CHROME  
 TUB001CRO/L

#### DESCRIZIONE TECNICA

- Scambiatore in alluminio con ottima stabilità termica nell'estrazione del caffè.
- Potenza di assorbimento di soli 450W con termostato di lavoro da 98°C.
- Elettrovalvola di carico/scarico a 3 vie.
- Gruppo di chiusura in verticale per dare alla macchina maggiore stabilità nella chiusura del gruppo.
- Compensatore brevettato, posto nella parte inferiore, che permette una chiusura senza sforzo e con una pressione costante nel tempo.
- Eliminati i trafiletti di acqua della cialda e lo sporco sulla parte sottostante (problema costante nei sistemi tradizionali).
- Eliminata la regolazione del gruppo, il compensatore si adegua autonomamente ad ogni erogazione agli schiacciamenti della guarnizione che avvengono nel tempo, con conseguente risparmio sulle parti di ricambio.
- Uniforme estrazione del caffè grazie alla stabilizzazione della pressione di esercizio.
- Facile accesso al gruppo per manutenzione tramite il pannello superiore fissato con sole due viti.

#### TECHNIC DESCRIPTION

- Aluminum heat exchanger with excellent thermal stability for coffee extraction
- Power absorption of only 450W with working thermostat of 98 °C
- Inlet/outlet 3-way solenoid valve
- Vertical group closure to give the machine more steadiness at group closure
- Patented Compensator, located in the lower part of the group which allows an effortless closure at constant pressure over time
- No water leaks from the filter: that means no dirt deposits on bottom side (problem that persists in traditional systems)
- No group adjustment, the compensator at each use adapts itself to the gasket squashing that occurs everytime, with consequent savings on spare parts
- Uniform extraction of the coffee due to the stabilization of the working pressure
- Easy access to group for maintenance purpose through the top cover, which is fixed by means of only two screws
- Spiral unit with special limescale-inhibiting GHA treatment

# MACINADOSATORI E MACCHINE DA CAFFÈ COFFEE GRINDERS AND COFFEE MACHINES



GRUPPO IN G.H.A  
G.H.A GROUP



GRUPPO IN  
OTTONE/ALLUMINIO  
BRASS/ALUMINUM  
GROUP

## GRUPPO IN G.H.A G.H.A GROUP

● TUB001N/L/GHA

Il trattamento GHA è la più recente ed innovativa tecnologia applicabile alle leghe di alluminio. GHA è un brevetto di origine giapponese ed anche brevetto europeo N°EP1207220, che consiste in una ossidazione anodica seguita da sigillatura delle microporosità con ioni d'argento la quale, oltre a conferire una caratteristica anticalcare alle superfici, conferisce alle superfici caratteristiche e prestazioni superlative. La tecnologia GHA, applicata in diversi settori alimentari, trova un principale impiego nel settore delle macchine da caffè perché conferisce alle superfici dei componenti particolari proprietà biotecnologiche preservando la macchina da ogni contaminazione e senza alcuna cessione nociva nell'acqua e nella miscela del caffè.

The GHA treatment is the most recent and innovative technology that can be applied to aluminum alloys. GHA is a patent of Japanese origin and also European patent no. EP1207220, consisting of an anodic oxidation with subsequent sealing of the micro-pores with silver ions: this offers a limescale-inhibiting feature on the surfaces and gives them superlative qualities and performance. The GHA technology, applied to various sectors of the food processing industry, is especially popular in the coffee machine manufacturing sector because it gives the surfaces of the components special biotechnological properties that protect the machine from all contamination and without producing any harmful effects on the water or on the coffee blend.

## PROPRIETÀ G.H.A G.H.A PROPERTY



- Elevata capacità antibatterica e antimuffa (battericida secondo le norme ISO 22196:2011 e JIS 2801:2010)
- Antiaderenza per il calcare
- Resistenza alla corrosione (1000 volte superiore all'alluminio)
- Elevata capacità antistatica
- Resistenza all'usura abrasiva
- Elevata conducibilità termica

- High antibacterial and mould-inhibiting capabilities (bactericidal complying with ISO 22196:2011 and JIS 2801:2010 standards)
- Inhibits the formation of limescale
- Corrosion resistant (1000 times superior to aluminum)
- Strong antistatic properties
- Resistant to abrasive wear
- High thermal conductivity

## GRUPPO IN OTTONE/ALLUMINIO BRASS/ALUMINUM GROUP

● TUB001N/L/OTT

Sui modelli TUBE a cialde è disponibile a richiesta il nuovo Gruppo Chiusura in Ottone ed Alluminio: la massima semplicità possibile nell'erogazione del caffè, rispettando le tradizioni del professionista, con la massima stabilità termica e facilità nell'eseguire le manutenzioni.

On all TUBE Coffee Pod machines a new coffee group made of brass and aluminum is available upon request: the most simple coffee delivery, considering the professional traditions, with maximum thermal stability and easy maintenance operations.

### TUBE CAPS

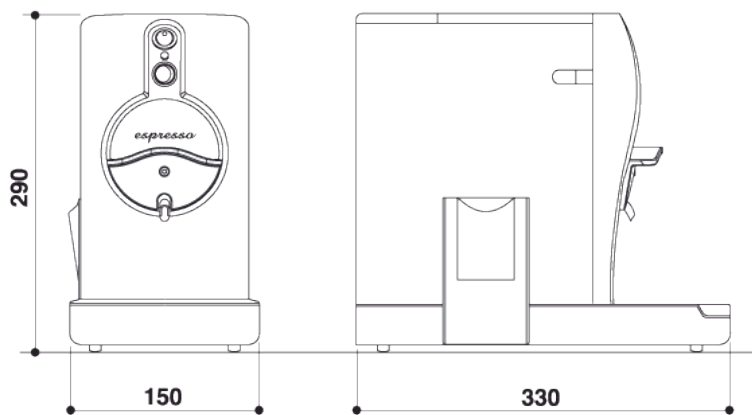

#### DATI TECNICI

Pompa ulka EP4FM: 20 bar  
 Serbatoio acqua: 2 litri  
 Assorbimento: 450 watt  
 Scambiatore: Alluminio  
 Termostato di lavoro: 98°C  
 Termostato di sicurezza: 145°C

#### TECHNIC INFO

Ulka pump EP4FM: 20 bar  
 Water tank: 2 liters  
 Power absorption: 450 watt  
 Exchanger: Aluminum  
 Working thermostat: 98°C  
 Security thermostat: 145°C

● CAPS001N/L CAPS001N/110V/L  
 NERO BLACK NERO BLACK

#### DESCRIZIONE TECNICA

- Scambiatore in alluminio con ottima stabilità termica nell'estrazione del caffè.
- Potenza di assorbimento di soli 450W con termostato di lavoro da 98°C.
- Elettrovalvola di carico/scarico a 3 vie.
- Gruppo di chiusura in verticale per dare alla macchina maggiore stabilità nella chiusura del gruppo.
- Compensatore brevettato, posto nella parte inferiore, che permette una chiusura senza sforzo e con una pressione costante nel tempo.
- Eliminati i trafiletti di acqua della cialda e lo sporco sulla parte sottostante (problema costante nei sistemi tradizionali).
- Eliminata la regolazione del gruppo, il compensatore si adegua autonomamente ad ogni erogazione agli schiacciamenti della guarnizione che avvengono nel tempo, con conseguente risparmio sulle parti di ricambio.
- Uniforme estrazione del caffè grazie alla stabilizzazione della pressione di esercizio.
- Facile accesso al gruppo per manutenzione tramite il pannello superiore fissato con sole due viti.

#### TECHNIC DESCRIPTION

- Aluminum heat exchanger with excellent thermal stability for coffee extraction
- Power absorption of only 450W with working thermostat of 98 °C
- Inlet/outlet 3-way solenoid valve
- Vertical group closure to give the machine more steadiness at group closure
- Patented Compensator, located in the lower part of the group which allows an effortless closure at constant pressure over time
- No water leaks from the filter: that means no dirt deposits on bottom side (problem that persists in traditional systems)
- No group adjustment, the compensator at each use adapts itself to the gasket squashing that occurs everytime, with consequent savings on spare parts
- Uniform extraction of the coffee due to the stabilization of the working pressure
- Easy access to group for maintenance purpose through the top cover, which is fixed by means of only two screws
- Spiral unit with special limescale-inhibiting GHA treatment

# MACINADOSATORI E MACCHINE DA CAFFÈ COFFEE GRINDERS AND COFFEE MACHINES

## PALLINA



PALLINA STANDARD

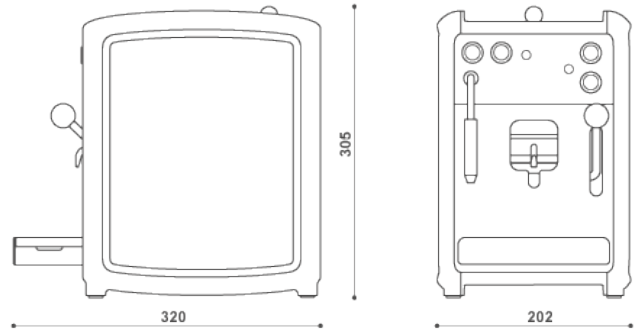

### DATI TECNICI

Voltaggio: 230V/50HZ  
Potenza: 450W  
Capacità serbatoio: 2 Lt  
Peso: 6 Kg  
Pompa a vibrazione  
Scambiatore di calore in ottone  
Optional: porta cialde da 38 mm

### TECHNIC INFO

Voltage: 230V/50HZ  
Power: 450W  
Tank capacity: 2 Lt  
Peso: 6 Kg  
Vibration pump  
Brass heat exchanger  
Optional: 38 mm pod holder

### COLORI DISPONIBILI AVAILABLE COLOURS

● PAL001N PAL007N(110V)  
NERO BLACK NERO BLACK

● PAL001B PAL007B(110V)  
BIANCO WHITE BIANCO WHITE



PALLINA VAPORE

### DATI TECNICI

Voltaggio: 230V/50HZ  
Potenza: 1250W  
Capacità serbatoio: 2 Lt  
Peso: 8 Kg  
Pompa a vibrazione + micropompa  
Doppio scambiatore di calore  
Circuito vapore indipendente  
Optional: porta cialde da 38 mm

### TECHNIC INFO

Voltage: 230V/50HZ  
Power: 1250W  
Tank capacity: 2 Lt  
Peso: 8 Kg  
Vibration pump + micropump  
Brass heat exchanger  
Independent steam system  
Optional: 38 mm pod holder

### COLORI DISPONIBILI AVAILABLE COLOURS

● PAL002N PAL008N(110V)  
NERO BLACK NERO BLACK

● PAL002B PAL008B(110V)  
BIANCO WHITE BIANCO WHITE

### DESCRIZIONE TECNICA

- Chiusura gruppo con il minimo sforzo • Assenza di perdite d'acqua nella zona cialda con conseguente assenza di sporco • Minimo ingombro
- Compensazione automatica del gruppo ad ogni erogazione • Massima uniformità di estrazione del caffè • Facile manutenzione

### TECHNIC DESCRIPTION

- Closed group with minimal effort • No water leaks in the pods resulting in the absence of dirt • Automatic compensation on brewing coffee group • Maximum uniform coffee extraction • Minimum space • Easy maintenance

## PALLINA TWIN

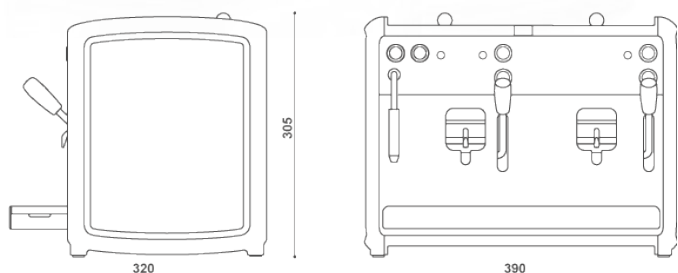

### DATI TECNICI

Voltaggio: 230V/50HZ  
Potenza: 1700W  
Capacità serbatoio: 2+2 Lt  
Peso: 16 Kg  
Pompa a vibrazione + micropompa  
Doppio scambiatore di calore  
Circuito vapore indipendente  
Optional: porta cialde da 38 mm

### TECHNIC INFO

Voltage: 230V/50HZ  
Power: 1700W  
Tank capacity: 2+2 Lt  
Peso: 16 Kg  
Vibration pump + micropump  
Brass heat exchanger  
Independent steam system  
Optional: 38 mm pod holder

### COLORI DISPONIBILI AVAILABLE COLOURS



PAL020N/1  
NERO BLACK



PAL020B/1  
BIANCO WHITE

### DESCRIZIONE TECNICA

- Chiusura gruppo con il minimo sforzo
- Assenza di perdite d'acqua nella zona cialda con conseguente assenza di sporco
- Minimo ingombro
- Compensazione automatica del gruppo ad ogni erogazione
- Massima uniformità di estrazione del caffè
- Facile manutenzione

### TECHNIC DESCRIPTION

- Closed group with minimal effort
- No water leaks in the pods resulting in the absence of dirt
- Automatic compensation on brewing coffee group
- Maximum uniform coffee extraction
- Minimum space
- Easy maintenance



## MONTALATTE STAR

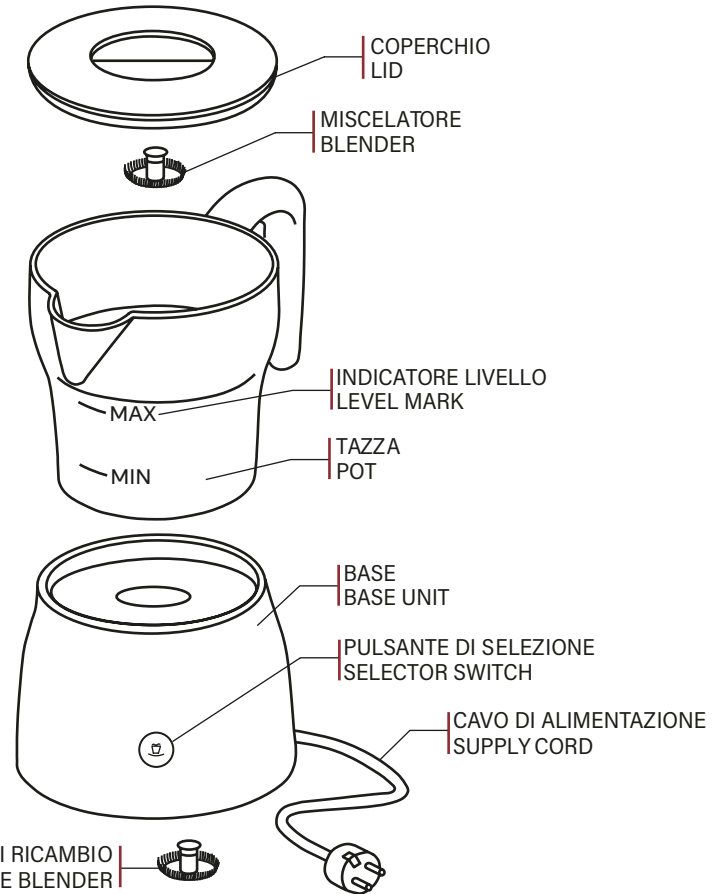

● V635/4  
NERO BLACK

### DATI TECNICI

Potenza/Assorbimento  
600-650W 220-240V 50-60Hz  
Capacità contenitore 100-250ml  
Lattiera con rivestimento antiaderente  
Non lavabile in lavastoviglie

### TECHNIC INFO

Power/Absorbition  
600-650W, 220V, 50-60Hz  
Tank capacity: 100-250ml  
Creamer with nonstick coating  
Not dishwasher safe

Il montalatte Star è lo strumento ideale per ottenere in modo semplice, rapido e pulito una crema di latte meravigliosamente soffice e cremosa per cappuccino, caffè macchiato, latte macchiato, cioccolato caldo o specialità fredde come caffè shakerato cioccolato freddo e molto altro. Realizzato in un elegante design, il Montalatte Star è complemento ideale per qualsiasi macchina da caffè e allo stesso tempo un accessorio indispensabile per tutti gli amanti delle specialità di tendenza. Semplice da usare, con un solo pulsante prepara in pochi secondi bevande calde e fredde da gustare in ogni momento

The Star milk frother is the ideal tool for easily, quickly and cleanly obtaining wonderfully soft and creamy milk froth for cappuccino, latte macchiato, hot chocolate or cold specialties such as shaken coffee iced chocolate and much more. Made in an elegant design, the Montalatte Star is an ideal complement to any coffee machine coffee machine and at the same time an indispensable accessory for all trendy speciality coffee lovers. Simple to use, with just one button it prepares hot and cold drinks in seconds to be enjoyed anytime

### FUNZIONI PRINCIPALI

#### MAIN FUNCTIONS



SCALDA E MONTA  
HEATER AND FROTHER



MONTA A FREDDO  
COLD FROTHINGH



FUNZIONE PER CIOCCOLATA CALDA  
HOT CHOCOLATE MODE

# MACINADOSATORI E MACCHINE DA CAFFÈ

## COFFEE GRINDERS AND COFFEE MACHINES

### Moka al G.H.A.®



G.H.A.® "Golden Hard Anodizing" il quale consiste nella realizzazione di una speciale ossidazione dura o semidura dell'alluminio, con sigillatura agli ioni d'Argento, che uniscono alle già ottime caratteristiche dell'ossido di alluminio le particolari proprietà del nobile metallo, rendendo la superficie trattata antibatterica, antiusura e anticorrosione.

innovative patent called G.H.A. "Golden Hard Anodising", which consists of the realization of the special hard or semi-hard aluminum oxidation with the addition of silver ions, combining the excellent properties of aluminum oxide produced by the company and the particular properties of Silver rendering the surface antibacterial, anti corrosion and anti wear.



MK002/GHA  
2 TAZZE 2 CUP

MK004/GHA  
4 TAZZE 4 CUP

MK007/GHA  
7 TAZZE 7 CUP



Moka "Squisita" con trattamento G.H.A agli ioni di argento eseguito sul filtro e sulla caldaia. Questo trattamento evita il rilascio di metalli nel caffè, impedisce la formazione di muffe nella caldaia ed è resistente al calcare, garantendo nel tempo un caffè privo di contaminazioni e dal sapore unico.

Moka "Squisita" with G.H.A silver ion treatment performed on the filter and boiler. This treatment prevents the release of metals in the coffee, prevents the formation of mould in the boiler and is resistant to limescale, guaranteeing contamination-free coffee with a unique flavour over time.

### MOKA DOPO 1 ANNO DI UTILIZZO MOKA AFTER 1 YEAR OF USE

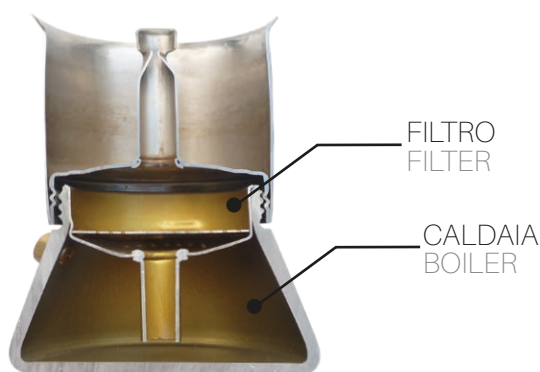

MOKA SQUISITA

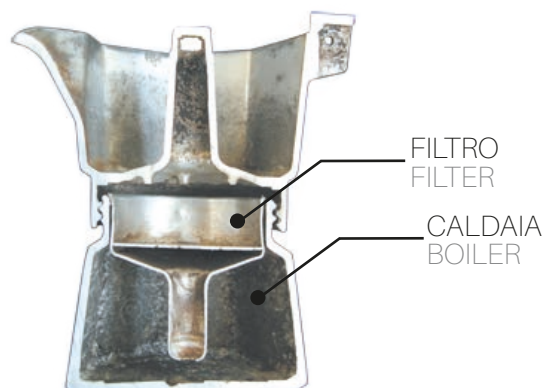

MOKA TRADIZIONALE  
Formazione di muffe, funghi e calcare  
Mould, fungus and limescale formation

SCOPRI TUTTI I NOSTRI CATALOGHI  
SUL SITO [WWW.RICAMBIGARDOSI.IT](http://WWW.RICAMBIGARDOSI.IT)



Macchine solubili



Catalogo acque

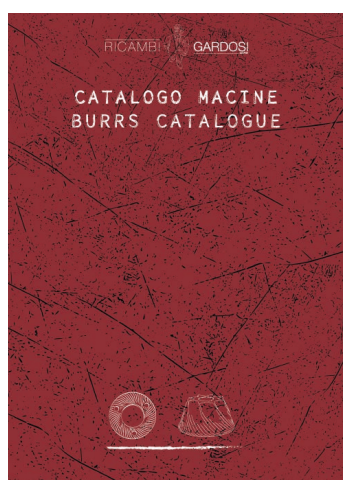

Catalogo macine



Catalogo OCS



**Sede commerciale e amministrativa:**  
Via Prati 3/D - 40069 Zola Predosa (BO) Italy  
**Telefono:** +39 051 756075 - **Fax:** +39 051 756640  
**Email:** [info@ricambigardosi.it](mailto:info@ricambigardosi.it)  
**Sito web:** [www.ricambigardosi.it](http://www.ricambigardosi.it)

E' vietata la riproduzione, anche parziale, in qualsiasi forma e con qualsiasi mezzo, compreso le fotocopie, senza autorizzazione scritta della Ricambigardosi S.r.l. Ogni violazione verrà perseguita a termini di legge. Per una migliore evasione degli ordini, citare sempre il numero di codice.

The reproduction or even partial reproduction of the same, in form, or by any means including photocopying, is expressly forbidden without the written consens of Ricambigardosi S.r.l. Any violation of these conditions will be subject to legal action. In order to assist order process always quote the code number



Tel. +39 051 756075



[www.ricambigardosi.it](http://www.ricambigardosi.it)



[info@ricambigardosi.it](mailto:info@ricambigardosi.it)



Via Prati 3/D - 40069 Zola Predosa (BO) Italy